

TABLE OF CONTENTS

1.	INTRODUCTION	5
2.	BD8 OPERATIONAL FEATURES.....	6
3.	PLANNING YOUR TRAIN DETECTION SYSTEM.....	7
3.1	PROTOTYPICAL SIGNALING SYSTEMS.....	7
3.2	SPECIAL MODEL RAILROAD APPLICATIONS	9
4.	CONVERTING TO COMMON RAIL WIRING.....	10
4.1	ELECTRICALLY INDEPENDENT CABS.....	11
4.2	FINDING THE CAB COMMON OUTPUTS.....	11
4.3	INSTALLING THE LAYOUT COMMON WIRE	12
4.4	CONNECTING NON-DETECTED BLOCKS.....	13
5.	POWER ROUTING THROUGH SWITCHES	14
6.	INSTALLING YOUR BD8.....	17
6.1	PHYSICAL INSTALLATION OF THE BD8 BOARD	20
6.2	SELECTING THE WIRE SIZES	22
6.3	CONFIGURING YOUR BD8 DETECTOR	24
6.3.1	NORMAL OPERATIONAL MODES.....	24
6.3.2	SELF TEST MODES	25
6.3.3	SOFTWARE VERSION NUMBER.....	26
6.4	CONNECTING TO THE TRACK BLOCKS.....	28
6.5	CONNECTING THE OUTPUTS	29
6.6	STANDING TRAIN DETECTION	32
6.7	TESTING YOUR BD8 DETECTOR INSTALLATION	34
6.8	TROUBLE SHOOTING SUGGESTIONS.....	34
7.	CUSTOMER SUPPORT	38

7.1	TECHNICAL ASSISTANCE.....	38
7.2	LIMITED WARRANTY	38

LIST OF FIGURES

FIGURE 3-1	TYPICAL ABS-APB BLOCK SIGNALS.....	8
FIGURE 3-2	TYPICAL CTC SIGNALS.....	8
FIGURE 3-3	HIDDEN JUNCTION DETECTION.....	9
FIGURE 3-4	HIDDEN HOLDING OR STAGING YARD.....	10
FIGURE 4-1	TAP WRE CONNECTED TO LAYOUT COMMON.....	12
FIGURE 5-1	POWER ROUTING SWITCH SET FOR MAIN LINE.....	14
FIGURE 5-2	POWER ROUTING SWITCH SET FOR SIDING.....	15
FIGURE 5-3	POWER ROUTING AND SEPARATE SIDING DETECTION.....	15
FIGURE 5-4	POWER RAIL ROUTING TO MAIN LINE.....	16
FIGURE 5-5	POWER RAIL ROUTINE TO SIDING.....	16
FIGURE 5-6	POWER ROUTING WITH STRAIGHT STOCK RAIL COMMON.....	16
FIGURE 6-1	DC CONTROL WITH BD8 DETECTOR BOARD.....	18
FIGURE 6-2	COMMAND CONTROL WITH BD8 DETECTOR BOARD.....	18
FIGURE 6-3	BD8 BOARD ASSEMBLY DIAGRAM.....	19
FIGURE 6-4	BD8 AND PANEL LAYOUT READY.....	21
FIGURE 6-5	COMMAND CONTROL JUMPER POSITIONS.....	24
FIGURE 6-6	DC CONTROL, OCCUPIED-VACANT OUTPUT.....	25
FIGURE 6-7	EAST-WEST REPORTING, SOUTH RAIL COMMON.....	25
FIGURE 6-8	EAST-WEST REPORTING, NORTH RAIL COMMON.....	25
FIGURE 6-9	READING THE SOFTWARE VERSION NUMBER.....	26
FIGURE 6-10	RAPID OUTPUT SEQUENCING.....	27
FIGURE 6-11	SLOWSPEED OCCUPIED-VACANT SEQUENCING.....	27
FIGURE 6-12	SLOWSPEED EAST-WEST SEQUENCING.....	28
FIGURE 6-13	DRIVING MULTIPLE LED'S FROM A SINGLE OUTPUT.....	29
FIGURE 6-14	LED RESISTOR INSTALLATION METHOD.....	31
FIGURE 6-15	CONNECTING INDUCTIVE LOADS.....	32
FIGURE 6-16	DC CONTROL WITH STANDING TRAIN DETECTION.....	33
FIGURE 6-17	ZERO OUTPUT THROTTLE MODIFICATION.....	36

LIST OF TABLES

TABLE 6-1	RESISTANCE TABLE FOR WRE.....	22
TABLE 6-2	COMMON RAIL AND OUTPUT CONNECTIONS.....	23
TABLE 6-3	GENERAL PURPOSE BD8 CONNECTIONS.....	23
TABLE 6-4	RECORD OF SOFTWARE VERSION NUMBER.....	26

APPENDICES

APPENDIX I	TERMINOLOGY.....	39
APPENDIX II	OPERATIONAL FEATURES.....	42
	1) CURRENT SENSING.....	42
	2) TYPES OF OUTPUT.....	42
	OUTPUT CAPACITY.....	42
	OCCUPIED-VACANT DETECTION.....	43
	DIRECTIONAL DETECTION.....	43
	LED ACTIVATION.....	44
	LOGIC SIGNAL ACTIVATION.....	44
	RELAY ACTIVATION.....	44
	3) BUIL-IN SELF TEST.....	44
APPENDIX III	OCCUPANCY DETECTION AND REPORTING.....	45
	1) OPTICALLY BASED SYSTEMS.....	45
	2) MAGNETICALLY BASED SYSTEMS.....	45
	3) SWITCHED ELECTRICAL CONTACTS.....	46
	4) CURRENT DETECTION SYSTEMS.....	46
	RELAY CURRENT SENSING.....	46
	TRANSISTOR CURRENT SENSING.....	47
	DIODE CURRENT SENSING.....	47
	ISOLATED CURRENT SENSING.....	48
APPENDIX IV	TRAIN CONTROL SYSTEMS.....	49
	1) DC CONTROL SYSTEMS.....	49
	TWO RAIL SWITCHED SYSTEMS.....	50
	COMMON RAIL SYSTEMS.....	50
	2) COMMAND CONTROL SYSTEMS.....	52

LIST OF FIGURES

FIGURE 1	TWO-RAIL SWITCHED CAB CIRCUITS.....	50
FIGURE 2	COMMON RAIL LAYOUT WIRING.....	51
FIGURE 3	COMMAND CONTROL LAYOUT WIRING.....	52

LIST OF TABLES

TABLE 1	DIRECTION AND RAIL USAGE.....	41
TABLE 2	OUTPUTS FOR DIRECTIONAL DETECTION MODE.....	44

1. INTRODUCTION

The BD8 Block Occupancy Detector is the latest in train detection systems. It works with layouts using either Command Control or DC Control systems for operating trains. In addition, for DC Control systems, the BD8 can report block status in either "OCCUPIED-VACANT" form, or it can report in "VACANT-STANDING-EAST-WEST" form.

With the OCCUPIED-VACANT form of output, the BD8 is all you need for two color signaling. The VACANT-STANDING-EAST-WEST form of output is particularly helpful with hidden track. By having two LED's on your control panel, both will be on if the block is occupied and no cab is selected; when you select a cab, only one will turn on to indicate the direction the train will move.

Best of all, because of the advanced techniques used, the BD8 board will provide train detection in 8 different blocks. And will do this for about the same cost as one or four normal block occupancy detector boards. A high level of electronic integration offers the BD8 complete built-in test functions, power supply and PC board edge connector.

We realize that most model railroaders have railroading as a hobby - not electronics. To give you access to the latest electronic technology without getting you into the electronics field, your BD8 comes to you completely assembled and tested. You don't have to have any knowledge of electronics to use all of the board's features. Simply follow the detailed instructions in this manual to connect the board's 8 inputs to your blocks for train detection, and the 16 outputs to your signals or other devices. Depending on how your layout is currently wired, it may involve no more than taping into 8 block common rail wires, and adding 2 wires per block to your signals!

2. BD8 OPERATIONAL FEATURES

The BD8 Block Occupancy Detector is the latest state of the art device for sensing the presence of trains in sections of track, and providing control signals to activate signals or other devices on the layout.

- a. The capacity of each BD8 is to detect trains and control color trackside signals from up to 8 separate blocks.
- b. Train detection is by current sensing. The BD8 will see the train no matter how long or short or how twisted the track is in the block.
- c. The BD8 works with your layout control system - either DCC Cab control or Digital Command Control.
- d. Direct output of both OCCUPIED and VACANT status - you can operate two color signals with no additional hardware.
- e. BUILT-IN SELF-TEST provided to help with the installation and troubleshooting, and identify specific problems.
- f. There is a significant output capacity to operate both trackside signals and control panel indicators with no additional hardware.
- g. Output flexibility - you can operate LED's, incandescent bulbs or relays for direct control of signals and other special features or use the BD8 to provide logic signals to other circuitry or a computer interface if you wish.
- h. Modularity – You can add as many BD8 boards as you need for your layout. Each will handle 8 or more blocks.
- i. Furnished assembled and tested. Just use the mounting hardware and card edge connector included with each unit, and follow the instructions, and you will have state of the art train detection and signaling system.
- j. Cost - there is NO other comparable train detection system with as low a cost per block as the BD8 - except our BD16 Block Occupancy Detector Board for 16 blocks!
- k. Power supply can be bought additionally from The Signaling Solution, to suit your requirements.
- l. The printed manual can be ordered for \$7.00. The online version of the manual can be downloaded for free from The Signaling Solution, Inc. website.

Refer Appendix II for further details on the operational features.

Some special features with respect to DCC also include the following:

- a. Our detection boards never need sensitivity adjustments. The boards are sensitive enough to detect a tightened finger placed on the track, but do not detect high humidity or require periodic sensitivity adjustments.
- b. Each detector element has a current rating of 3 amps (continuous duty), and will withstand brief overloads of up to 10 amps.
- c. Detects trains by monitoring current throughout a block. Trains are detected anywhere in the block, not just as they pass a photo detector or magnetic detector.

3. PLANNING YOUR TRAIN DETECTION SYSTEM

Now is the time to plan your train detection system. You probably have a general idea of what you would like to accomplish. But, to help you clarify any issues that may be undefined, we would like to present some ideas that may be helpful.

The prototype railroads have only one purpose for their signal systems to help trains stop safely before reaching another train, and obstruction, or other unsafe situation. Naturally, we may want to include signaling to add realism to our layout. But there are aspects about model railroads that have no prototypical equivalent. For example, how often does a prototypical train pull into a hidden staging yard, under a hydrocal mountain? We will also give some suggestions about using train detection to help you operate your layout, especially those portions which are hidden from view.

3.1 PROTOTYPICAL SIGNALING SYSTEMS

In the succeeding paragraphs, we have provided just enough information to help get you started. There are a number of books and magazine articles available that will help you expand your knowledge of the subject. And, if you are attempting to model a specific prototype in a specific era, the final guide will be the railroad's Employee Time Table and Rule Book. While the figures and signal arrangements may be considered "typical" or "AAR standard", each individual railroad is free to add to or even modify the AAR standards as it sees fit.

The main focus of a prototype signaling system is to help the engineer stop his train safely. But they also want trains to be able to move as quickly as possible when they are not stopping. The key issue is stopping distance. There are three primary factors that determine stopping distance: the weight of the train, the speed of the train, and the slope of the track. Heavier trains take longer distances to stop, faster trains take longer to stop, and trains going down hill take longer to stop.

Even if we are modeling a prototype signaling system, as modelers, our stopping distances are measured in inches no matter what our speed, and our available space is small. So, we resort to selective possession. We will normally have our blocks as long as the typical train on our layout. Our passing tracks are usually the same length as well.

Before the advent of Centralized Traffic Control (CTC) systems, railroads used Automatic Block Signaling (ABS) to signal for one direction of traffic, and Absolute-Permissive Block Signaling (APB) to signal for two directions of traffic. For both of these systems, the Timetable identified where and where stops and passes were to take place, and the rules of train superiority, by class and direction, told which crews to take the siding and which to use the main. Any exceptions to the timetable, such as temporary routings, extra trains, movements opposed to the normal traffic flow, were handled using written train orders. The train crews were responsible for setting the track switches as they came to sidings, and for leaving them in the normal position when leaving.

With CTC installations, a remotely located dispatcher controls the switches and signals at passing tracks, but usually not at industrial spurs. The timetable is still used to provide the schedule for the trains. Stops and passes are controlled directly by the dispatcher; the rules of train superiority are suspended.

One simple way to tell which type of signaling the prototype is using is to look at the signals at the entrance and exit of passing tracks. In ABS and APB systems, there are two signals, one facing each way, located near the switch points. These are called head signals. Trains on the frog side of the switch will stop before reaching the fouling point if the signal they see shows STOP. The signal they face as they approach from the point side indicates the condition of the main line block. The siding is normally not signaled.

The signal seen when leaving the passing track area is an absolute signal. If it displays STOP, a train is not allowed to pass. You will normally find a telephone located near absolute signals so the crew can phone for instructions if they find an unexpected STOP aspect.

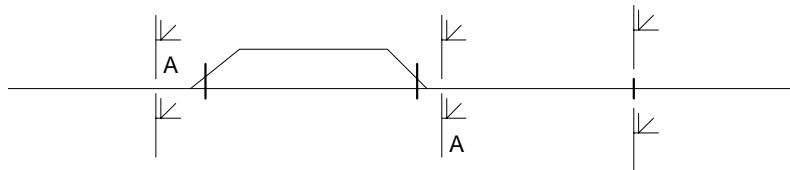

Figure 3-1 Typical ABS-APB Block Signals

With CTC installations, there are usually three signals protecting the end of a passing track. Since the timetable is no longer used to determine train superiority, the signals are used by the dispatcher to issue "orders" to the crews. The signal seen when approaching the points will show CLEAR to indicate a train routing on the main, will show APPROACH to indicate a routine on the siding, and STOP to indicate STOP. Some railroads will have a two-head signal, with the upper head signaling use of the main, and the lower head signaling use of the siding. Thus, GREEN or RED routes a train onto the main; RED over GREEN or RED over YELLOW will route the train onto the siding. The yellow aspect indicates using approach speed into the siding.

On the frog side, there will be one signal for both tracks. These are both absolute signals, and the dispatcher will set one of these signals to display either CLEAR or APPROACH to allow a train to depart.

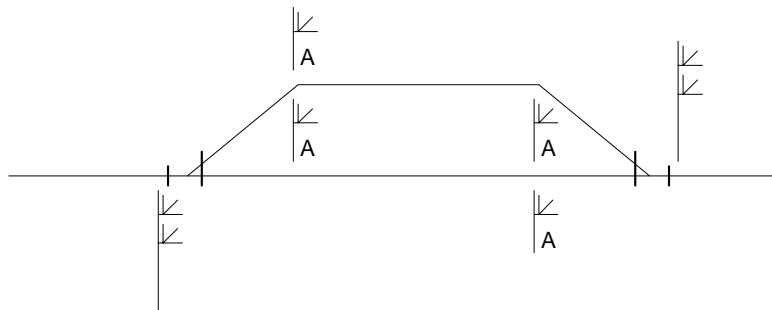

Figure 3-2 Typical CTC Signals

It should be noted that, except at passing tracks and junctions, where the dispatcher issues "orders" by signal indication, the remaining signals are normal ABS-APB signals. And even the dispatcher controlled signals will have their aspects overridden by the ABS-APB detection circuits if trains are in the blocks ahead of the signals.

With CTC, the trackcircuits that detect the trains will control the aspect display at trackside; but they will also indicate occupied blocks on the dispatcher's panel so he can see where trains are. A special track circuit detects trains which are on dispatcher controlled switches and prevents him from throwing a switch beneath a train. This is indicated by the short detection blocks containing the switches in Figure 3-2. Usually, as soon as a train enters the switch itself, all three of the signals will automatically return to STOP. This automatically protects the rear of the train. Also, no matter what the type of signaling, the industrial tracks along the way are interlocked into the signal system. If the switch to a spur or the derail on the spur itself is not in their safe position, the signals protecting the entrances to the block will display STOP. Normally, this will be a permissive stop, allowing the crew to stop, and then proceed at restricted speed watching for a train or obstruction.

3.2 SPECIAL MODEL RAILROAD APPLICATIONS

As modelers, we can include all of the signaling the prototype uses, especially along our visible track. But much of our track is hidden. It really doesn't make sense to install trackside signals in places where neither the operators nor spectators can see them. But it does make sense to provide train detection and display block occupancy to help us operate trains in our hidden track.

There are two typical situations that we have on our layouts that would benefit from occupancy display. When installed as shown in the next several figures, train detection will allow you and your operators to function as smoothly over hidden track as you do with the visible track.

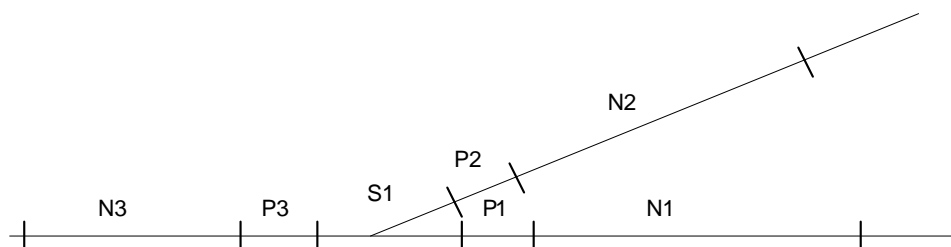

Figure 3-3 Hidden Junction Detection

In this figure, the three blocks labeled N1, N2 and N3 are "normal" length blocks, probably about a train's length. The blocks P1, P2 and P3 are "positioning" blocks. Each is about the length of an engine, and they are located so that they protect the fouling points of the switch. And block S1 is the switch itself, from ahead of the points to a little beyond the fouling point on the frog side. Each of these blocks has an occupancy detector connected, which controls a single "occupied" LED on a panel which is visible to everyone operating trains in the junction area. The display panel would probably depict the track in the area in schematic form.

In normal operation, an engineer might be told to "hold at the junction." He would move his train toward the junction, watching the display panel to see where his train was. As soon as the positioning block shows occupied, he stops his train. If the switch block shows occupied, he has run through the positioning block and is fouling the switch. He simply backs up until the switch shows vacant and the positioning block still shows occupied.

The next situation that we modelers have that the prototype doesn't have is a hidden holding yard. Its arrangement of detection blocks, the display of occupancy on a panel and the method of operation are very similar.

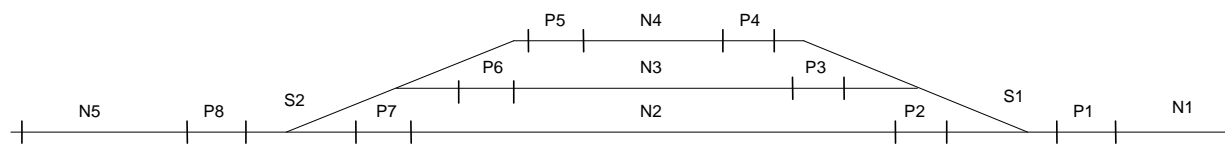

Figure 3-4 Hidden Holding or Staging Yard

Again, the blocks labeled "N" are normal blocks, those labeled "P" are positioning blocks, and the switch blocks are labeled "S." Also, the block arrangements shown in these two figures are detection blocks. The power routing blocks, if you are using DC control, will include the consecutive "P" and "N" blocks.

4. CONVERTING TO COMMON RAIL WIRING

If your layout is already wired for common rail power distribution, your installation will be somewhat easier. But, even so, there may be some minor alterations in wiring, primarily involving power routing through switches under some conditions.

Begin by selecting your common rail. If your layout has already been wired using the common rail system, this step is done. All you need to do is remember which rail you picked!

The common rail can be either the north rail or the south rail, it really doesn't matter. Incidentally, just for clarity, this manual is written assuming that your layout is an East-West railroad. If you think of your railroad as a North-South railroad, we suggest that you temporarily think of it as East-West. This will make it easier to read the manual. Otherwise, this manual would be almost twice as big. Every paragraph would have to appear twice - once written with "East-West", and once with "North-South."

How do you know which is the north or south rail? It's very simple, really. Look at any section of track on your layout where a westbound train moves from right to left. The south rail is the rail closest to you; the north rail is the other rail. If your layout is an oval of some kind, Linn Westcott suggested many years ago that you envision a north pole in the center of the oval. The rail closest to the center would then be the north rail. If he had lived in the southern hemisphere, his suggestion may have been different, but it doesn't matter.

First, without common rail wiring, your layout wiring diagram probably look something like Figure 1 Two Rail Switched Cab Circuits. As you can see, each of the two outputs is routed through a cab select switch to the two rails of each block. There is no single wire shared by all of the cabs - each is totally independent. Not shown are wires, or switch points, used for routing power. Perhaps you have some additional toggle switches used to connect reverse loops or crossings.

There are several steps to go through in making the conversion. We recommend that you make the conversion in simple, easy to correct steps. Doing all of the rewiring and then testing to see if it all works is very macho - but

not very bright! Based on our experience with the conversion process, we are going to recommend a step-by-step approach which will minimize your aspirin consumption.

4.1 ELECTRICALLY INDEPENDENT CABS

Cab independence, of course, is essential to common rail. This lets us connect any one output terminal of each together without causing any problems. The most obvious indication that the cabs are electrically independent is simple to see. Any two cabs that have separate power cords are electrically independent.

If you have any of the dual throttle cabs on the market, you will have to do some experimentation to see if they are electrically independent. First with the unit unplugged from the wall and the throttle outputs disconnected from the layout, use an ohmmeter to check for continuity between the two throttles. Measure from each output of one throttle to each output of the other, and reverse the meter leads as well to make sure that there are no internal diodes connected. In all of these resistance checks look for infinite resistance or an open circuit indication. Any low resistance under 10 K ohms is a pretty good indication that the throttles are not independent.

Then, plug the power supply into the wall outlet, leaving it disconnected from the layout, and set the output voltage of each throttle to 3 volts. With your voltmeter on the 10-volt DC or higher scale, measure the voltage between each output of one throttle and each output of the other. This will give a total of four voltage readings.

In each case, you will read 0 volts if the throttles are independent; if they are not, you will measure +6 volts for one measurement, and -6 for another. If the two throttles in a dual power pack are not internally isolated you can use only one of them in your new wiring. Then, reconnect only one of the throttles if they are not independent, or both if they are independent.

4.2 FINDING THE CAB COMMON OUTPUTS

Once you have selected the common rail, identify which output of each cab is connected to the common rail through your cab select switches. Turn off all of the cabs for this next step. Pick any conveniently located block, remove any engines and cars from the block, and attach one of your ohmmeter leads to its common rail. Then, one at a time, select each cab and with the cab select switch for the block and with your other ohmmeter lead to the outputs of the cab. One of the outputs will show a very low resistance, probably less than an ohm. The other output will show a much higher resistance.

Confirm the reading by reversing the ohmmeter leads. In each case, the cab output currently connected to your common rail through the cab select switches will show a very low resistance. Mark the common rail output on each cab. Do this for all of your cabs: main line, yard or other local service cabs.

When this is done, let's do a sanity check. Make a quick and dirty temporary connection between all of the cab common rail outputs that you just identified. Then, operate a train over the layout, using each cab and taking each route, siding or spur. Everything should still work just as it always did.

If something isn't working that used to work, take the time now to identify the problem. There're only two things that could be wrong at this point. Either cabs that you thought were isolated really aren't, or the cab output you identified as being the common rail output was incorrect. Before proceeding, correct the problem.

4.3 INSTALLING THE LAYOUT COMMON WIRE

Next, we will install the layout common wire. Review Section 6.2 to choose the correct wire size to use. If in doubt, use the next larger size. Use stranded wire, as it's much easier to pull around joints, risers and L-girders. And it will probably be easier to install multiple runs of smaller gauge wire than one run of very heavy wire. For example, use four runs of 10-gauge wire rather than one run of 4-gauge wire. Both approaches give the same effective resistance, but 10-gauge wire is probably as heavy as you would want to work with. Of course, use copper wire, not aluminum. You will have to solder connections to the layout common, and copper is much easier to work with.

Then, run the layout common wire around your entire layout, bringing it near to all of the cabs, and close to all of the locations you have selected for BD8 installations. When the layout common is installed, make your permanent connections between the cab common outputs and the layout common.

Wherever you need to connect a tap wire to the layout common wire, carefully skin about one inch of the insulation off each of the common wires and strip a couple of inches of insulation off the end of the tap wire. Then take the stripped end of the tap wire and wrap a tight turn around each run of the layout common. Solder each of these turns to the layout common using rosin core solder. This is shown in Figure 4-1 Tap Wire Connected to Layout Common.

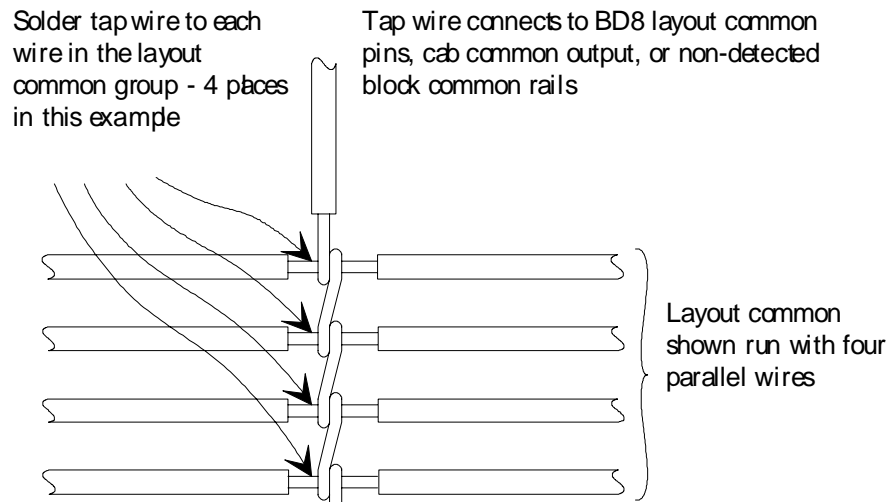

Figure 4-1 Tap Wire Connected to Layout Common

You may need a 100 watt or more iron or soldering gun to heat up 10 gauge wire enough to get a good connection. It's better to use a high wattage, and complete the connection quickly, than to use a low wattage iron

and take all day to heat the wires. This won't work well, and you'll probably have melted insulation all around the connections.

Be sure that you physically secure the bare wires so they can't move and possibly contact other circuits. Wrapping the connections with electrical tape may also be a good idea. This will save you trouble in the future. Again, do a sanity check by running your yard to see that everything still works. At this point, the only problems were probably caused by the physical disturbance that came from running the layout common wires. Since you really haven't changed your existing wiring, it should be easy to locate and fix the problems. Make sure everything is working before you continue.

4.4 CONNECTING NON-DETECTED BLOCKS

You will probably have blocks or other sections of track that are not going to be connected to your BD8 boards. This will normally be yard tracks and probably industrial sidings. At this time, you will connect the common rails of these areas of track to the layout common wire.

For your non-detected blocks we recommend that you make sure that each such block or section of track has gaps in the common rail to separate it from any adjacent detected blocks.

Connect these sections of track to the layout common one at a time, and then test what you did. This way, you can keep any problems from growing to unmanageable proportions. Also, by doing a little at a time, you can keep your layout operational while you make this conversion.

Select a non-detected block to reconnect. After the common rail has been separated by gaps from other blocks, disconnect all of your original feed wires from your cab select switches to the common rail. We suggest you cut these wires so that at least a few inches are connected to the rail and accessible. If you make a mistake and cut the wrong wire, you can splice the ends back together. If you can use the wire still attached to the rail then the connection to the layout common wire.

At this point, the common rail for the block should be completely isolated electrically. Verify this by connecting a cab to the block, and all adjacent blocks using proper cab select switches. Set the cab output for a few volts, and measure the voltage in the block from its common rail to its power rail. Check throughout the block, including any switches or crossings.

The only right answer is 0 volts. This shows that the common rail has been isolated. If you get a non-zero voltage reading, it means that there is still an original wire connecting the common rail back through the cab select switches to layout common. Or, you may not have put in all the gaps needed to isolate the rail. It's time to conduct a search and destroy mission to eliminate all of the old connections to the cab select switch, or to cut all necessary gaps.

You may still have some wires attached to the common rail. These will be wires that pick up the stock rails electrically and route them to switch machine contact for powering the frogs. Leave these wires in place.

When the common rail has been isolated from all of the original feed wires, connect it to the layout common. Attach a tap wire as described in the prior section, and connect the other end of the tap wire to the common rail

using the ends of the original feed wires left attached to the common rail. If the block is particularly long, you may want to use several tap wires from the layout common.

Note: At this time, the select switch is only feeding the power rail; the common rail is now being fed by the layout common wire.

Finally, finish work on the block by conducting another sanity check. Run an engine in, around and through the block using each of the cabs, checking each route. Fix any problems. If the engine does not run everywhere in the block, this will probably be due to missing a connection between a tap wire and one or more of the common rail wires. Or, you may have attached a tap wire to a power rail feed. This would result in a short circuit in the block, and the engine won't run anywhere as long as the select switch is set for the block.

Repeat this process for each non-detected block, checking as you go. While you are doing this, you are only taking one block out of service at a time and only long enough to complete its conversion. You don't have to cancel any of your operating sessions!

When you have finished all such blocks, go on to the section below, Power Routing Through Switches.

5. POWER ROUTING THROUGH SWITCHES

Train detection may also have an effect on your power routing through switches. Figure 5-1 shows a normal power routing switch aligned for the main line. As you can see, both siding rails are electrically connected to the power rail "P", and any train on the siding will see voltage and will therefore be stopped. An electrical contact is shown which operates along with the points to route power to the frog.

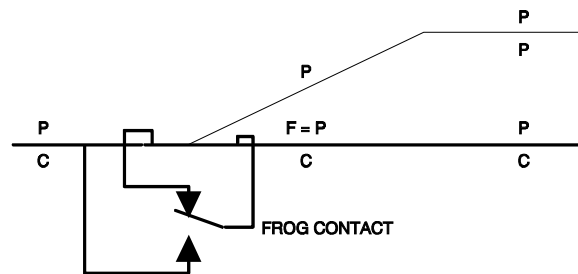

Figure 5-1 Power Routing Switch Set For Main Line

Figure 5-2 shows the switch aligned for the siding. Now, a train on the siding sees both power and common rails and can move, while a train on the main sees two common rails and cannot move. As long as we don't want to detect a train on the siding while the switch is set for the main everything is just fine. But, if we want to have a separate block on the siding, with a separate detector, the standard power routing won't work.

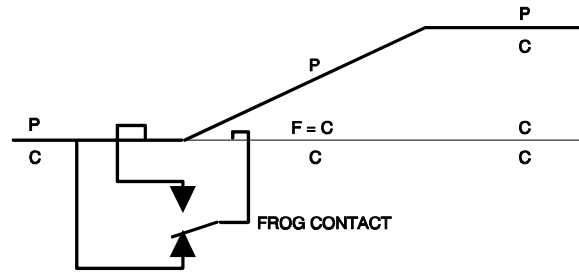

Figure 5-2 Power Routing Switch Set For Siding

Figure 5-3 shows the main track with separate siding detection on the siding using detector C, while detector A is looking at the main line. You can see that we need a gap in the siding common rail near the fouling point of the switch to separate the siding common rail from the main line block.

Here is where things get interesting. The common rail for the siding is always connected to layout common through the C block detector, and its power rails are simply a continuous stock rail through the switch. And, even with the switch set for siding, a train on the siding will run!

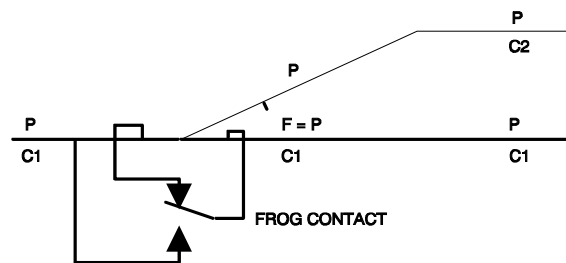

Figure 5-3 Power Routing and Separate Siding Detection

To solve this problem, we need to have an extra electrical contact that operates along with the switch to route the power rail through the switch. This means two single pole, double throw (SPDT) contacts are needed for a power routing switch with separate detection on the frog. One contact routes power to the frog, the second routes the power rail from the point side to one of the power rails on the frog side. This is shown below in Figure 5-4. Both of these contacts move along with the points. Everything in the figure is shown with the switch aligned for the main. Note: Both siding rails are gapped near the switch's fouling point, and the main line block's power rail is also gapped at the fouling point.

With the switch as shown, the lower contact is connecting the main block power rail to the frog (F). The upper contact is connecting the main block power rail to the part of the main block beyond the frog (rail P). The power rail on the siding block (PS) is not connected to anything (nc), and a train on the siding will be stopped. It could still be detectable by C2 if there was a source of current to detect. We'll show you how to do that in a just a bit.

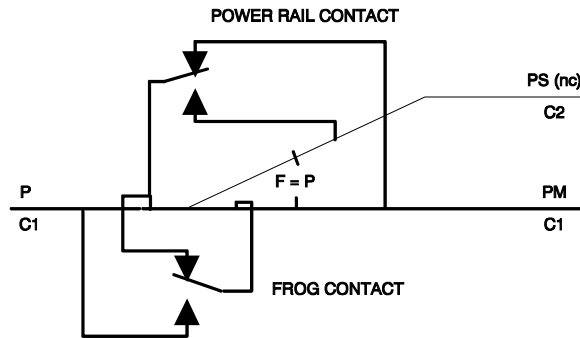

Figure 5-4 Power Rail Routing to Main Line

In Figure 5-5, the switch is aligned for the siding. Note that the contacts move with the points, and the frog (F) is now connected to the rail. The siding power rail (PS) is connected to the power rail for the main (P), and the main line power rail (PM) beyond the switch is not connected (nc). A train will now run on the siding, but remain stopped on the main.

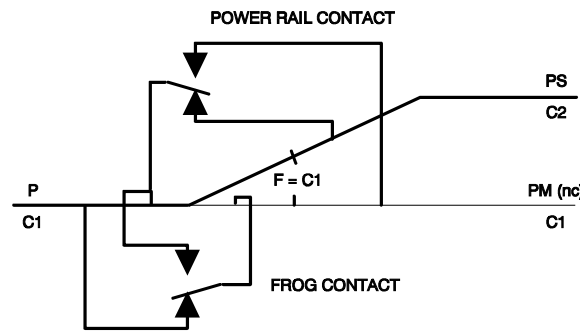

Figure 5-5 Power Rail Routine to Siding

Just for completeness, we'll show the switch wired with the straight stock rail as the power rail, and the curved stock rail as the common rail. In Figure 5-6, the common rails are connected to two separate detectors (C1 and C2). We assume that "P" is being fed by a cabselect switch, and is routed by the upper contact to the power rail (PM) in the main line block beyond the switch.

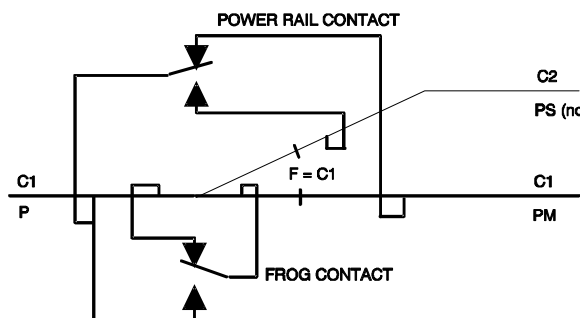

Figure 5-6 Power Routing With Straight Stock Rail Common

The power routing we have shown above is something that you will have to add to any of your switches that will have separate detection on frog side with power being routed through the switch. One at a time make the modifications to each of your switches that will operate the way. Again, after each is modified with the extra

electrical contact, do a sanity check and run a train through all related routes and make sure it runs when it should run, and stops when it should stop. If something doesn't work right, fix it. You have probably not wired one of the contacts properly, or have not cut the necessary gaps.

6. INSTALLING YOUR BD8

You have probably heard the adage "For Planning Prevents Poor Performance," and model railroading is no exception. Before doing anything on your layout, we recommend you plan your complete signaling installation, even if you have only purchased some of the detectors and signals you will eventually need.

1. First, make a drawing of your layout showing all of the tracks: main line, sidings, spurs, hidden, visible, built, or planned but not yet built.
2. Then, identify each separate detector block and give it a number from 0 to 7. If your layout needs more than one BD8, assign a letter to each BD8 (BD8-A for the first, BD8-B for the second, and so on), and label the blocks with the BD8 letter and block number. For example, if you have two BD8s, the first will have blocks labeled A0 through A7, and the second will have blocks labeled B0 through B7. Assign the labels any way you want. The purpose is simply to know how and where to connect the wires. This drawing will be the master signaling system drawing for your layout.
3. Before continuing here, if your layout is not already wired for common rail power distribution, follow the instructions in Section 4, CONVERTING TO COMMON RAIL WIRING. The steps have been planned out so that you can continue to operate your layout even if the conversion takes weeks or even months. There is no need to shut down your layout completely while installing signaling.
4. The next step is to connect your BD8 boards to your layout. There are two types of connections to make.
 - The first group of connections will connect the BD8 into your common rail circuit so that the BD8 can detect your trains. When you have finished connecting your BD8 into the common rail feeds to your detected blocks, your wiring will look something like if you are using DC control. It will look like if you are using command control. The steps in the remainder of this section will help you to complete the installation.
 - The second group of wires will connect your BD8 to your signals, display LED's or any other logic circuitry you may have. Since the connections to LED logic and relays are all slightly different, separate paragraphs below will describe the differences. These connections are not shown in the two figures below.

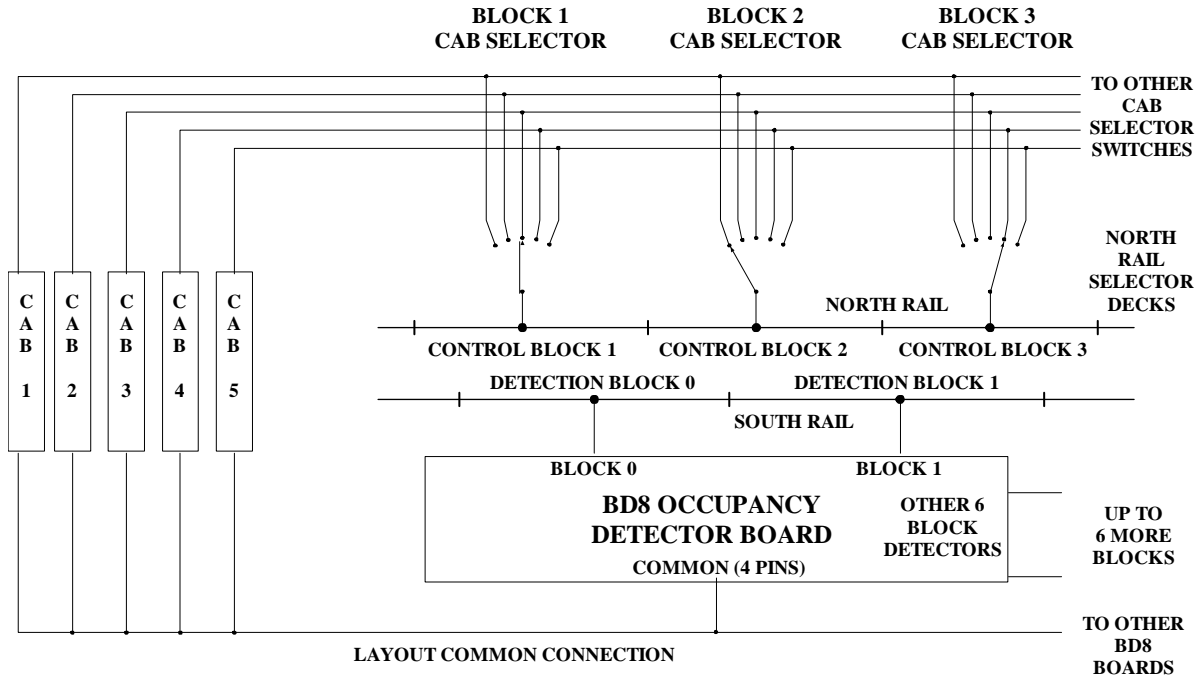

NOTE: Detection blocks (SOUTH rail) and control blocks (NORTH rail) can be different.
 Detection outputs from BD8 are not shown in this figure.

Figure 6-1 DC Control with BD8 Detector Board

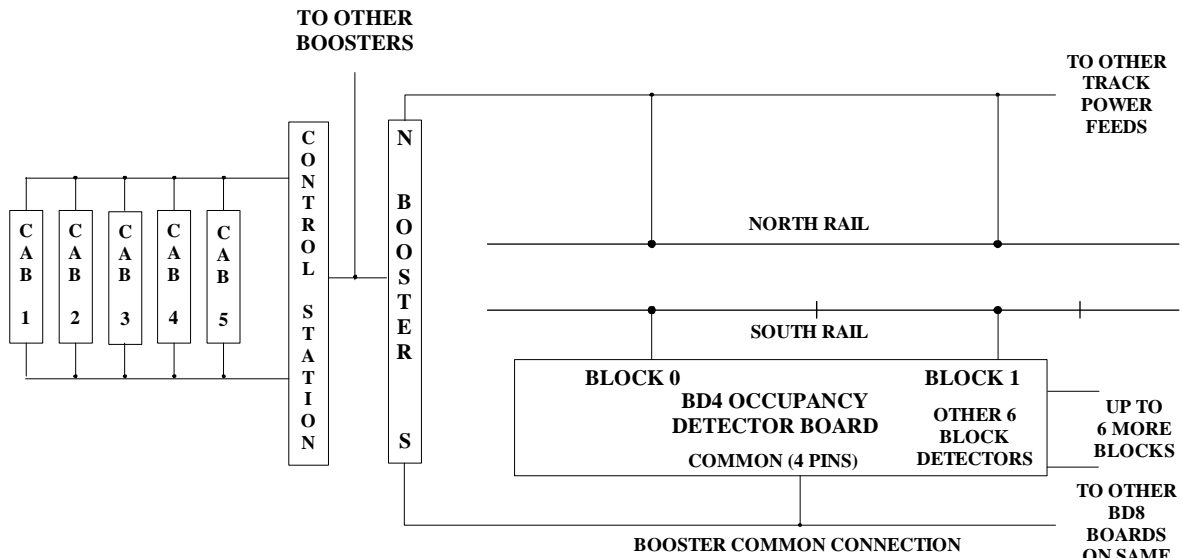

NOTE: Gaps are only used to isolate frogs, or to separate boosters.
 For DCC, do not make ANY connections between the outputs of separate boosters. For other forms of command control, see your system manual for instructions.
 Cab connections to control station depend on the specific command control system used.

Figure 6-2 Command Control with BD8 Detector Board

5. Connect only one end of one wire at a time and repeat that one step for each connection to be made and you can't lose.

Figure 6-3 BD8 Board Assembly Diagram below shows how your BD8 and related items will look when ready for installation. For your reference, the major items are identified individually

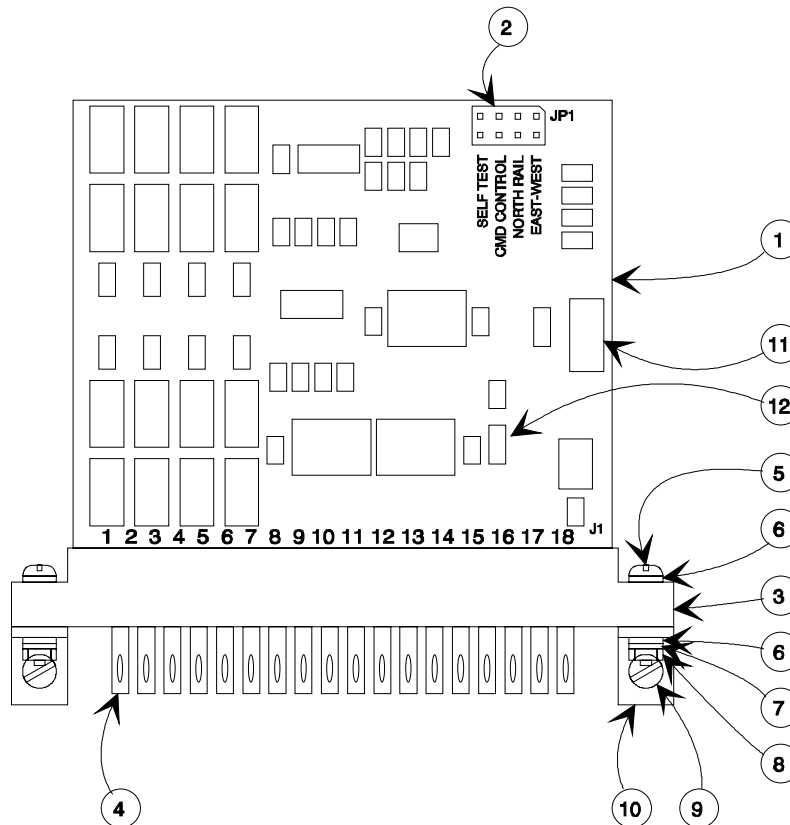

Figure 6-3 BD8 Board Assembly Diagram

The items shown are:

Item 1: BD8 Printed Circuit board, with top view shown.

Item 2: Mode plug with positions for four mode jumpers (none shown).

Item 3: Card edge connector, your BD8 plugs into this connector.

Item 4: Contact 1 of the 36 contact fingers on the card edge connector. Contact 1 is labeled on the connector itself, and corresponds to the top left contact on the PCB. Contact A is immediately below contact 1. The top row of contacts are numbered from 1 to 18; the bottom row is lettered A-V. Letters "G", "I", "O", and "Q" are not used.

Item 5: Pan Head #4-40 stainless steel machine screw (2 places) used to fasten card edge connector to the right angle mounting brackets.

Item 6: Flat #4 stainless steel washer (4 places) used to protect surfaces from the screws and lock washers.

Item 7: Internal tooth #4 lock washer (2 places) used to secure the mounting screws and brackets.

Item 8: Stainless steel #4-40 hex nut (2 places).

Item 9: Round head #4 wood screw (2 places) used to attach mounting brackets to the mounting panel.

Item 10: Right angle mounting bracket (2 places).

Item 11: The surface mounted voltage regulators.

Item 12: The LED blinks when the on-board power supply is functioning properly

6.1 PHYSICAL INSTALLATION OF THE BD8 BOARD

Figure 6-4 BD8 and Panel Layout Ready below shows the BD8 mounted to a flat wood panel ready for installation on your layout.

1. A piece of 1 x 6 six to eight inches long, or a similar size piece of plywood, is just fine. You will also need diagonal cutters, needle nose pliers, screw drivers, and a soldering iron with a maximum of 25 watt rating.
2. Then attach the panel in an easily accessible location on a table leg or front of an L-girder. You will find it much easier to prepare the panel as shown above your workbench. *Doing this under your layout will probably be more difficult.* Remember that you will be running wires from the board to the blocks and your signals or control panels.

3. Plan how the wires will be routed from the board and to the layout.

Suggestion: Use cable clamps to keep the wires from placing any strain on the card edge connector pins and out of the way.

4. Use a strain relief to protect the contacts on the card edge connector.

Suggestion: For the larger gauge wires for your tracks and layout common, we suggest you use a Rich Barrier Block part number 9-140. The current Digikey catalog (1-800-344-4539) lists this with their part number CBB109-ND. For the smaller gauge wires for your signals, a simple cable clamp will do. A nylon cable clamp from the Richco line (also available from Digikey) will do. They come in several diameters, so pick the right size for the wire bundle going to the signals. You want the clamp to hold the wires securely and keep them from putting strain on the connector pins.

Incidentally, the screw barrier strip is a good idea for troubleshooting. It makes it easy for you to disconnect blocks, or to swap BD8 detectors to aid in fault isolation. The small cost for such strips is well worth it.

5. If the distance from the BD8 and the blocks is particularly short, and your engines are equipped with low current can motors, you can probably run your common rail feed wires using 22 gauge wire. If you use stranded wire and a tight cable clamp to keep the wires from pulling on the connector contacts, you could connect directly to the card edge connector. See Section 6.2 for detail on selecting wire sizes. Since the wires to your signals will probably be 22 gauge or finer, a simple cable clamp will be adequate. Stranded wire will be easier to work with. You may want to consider using four conductor modular phone cord. It's available almost everywhere, and at a very low price. The four wires in the bundle are color-coded, while fairly fine, they are easy to work with.

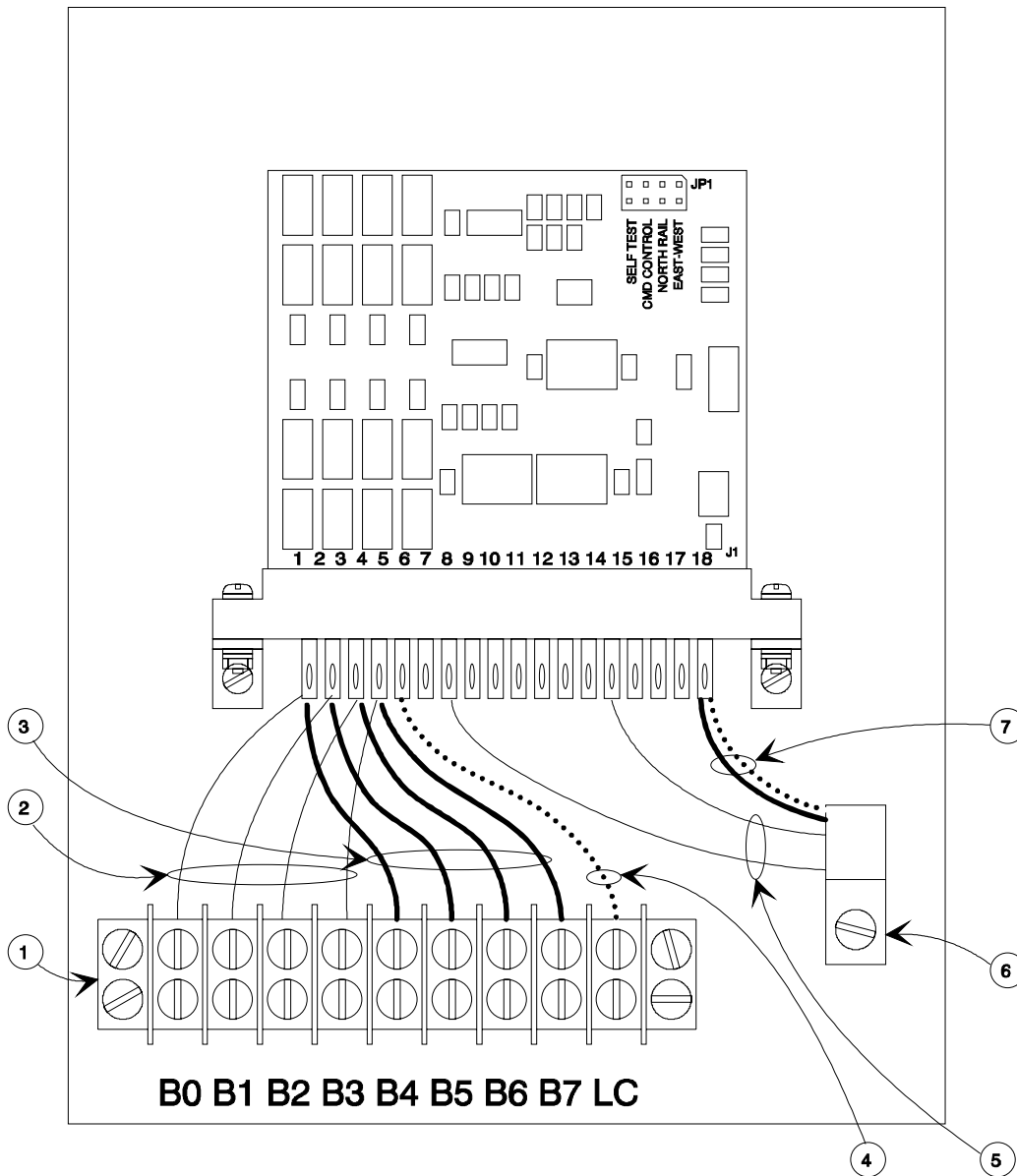

Figure 6-4 BD8 and Panel Layout Ready

The major items in Figure 6-4 are as follows:

Item 1: Screw barrier strip with 9 positions.

Item 2: Common rail wires for blocks 0-3 from contacts 1-4.

Item 3: Common rail wires for blocks 4-7 from contacts A-D.

Item 4: Layout common. Connect to at least 2 of the four contacts 5, 6, E or F.

Item 5: 16 occupied and vacant wires/signals on control panels.

Item 6: Nylon cable clamp, sized to clamp wires snugly

Item 7: Two wire power feed from wall mounted power supply provided with your BD8.

6.2 SELECTING THE WIRE SIZES

The contacts on the edge connector are used to connect to your layout. Five wires will go to the common rails of the eight blocks, 1 will go to the layout common, 16 will go to the red and green LED's, and 1 will connect the +5 volt supply to the LED and we will identify these connections in detail later. What is important now is that you plan for the wiring strain relief for the wires to protect the connector, and accessibility for maintenance, test and trouble shooting.

Because the current required to operate LED's, bulbs or relays is low, typically less than 0.1 amps, you can use wires for these circuits of 22 to 26 gauge with no problem. The wires carrying train current will probably have to be 18 to 22 gauge.

People sometimes wonder what size wire to use, and that's a good question. A general rule of thumb is to use heavy enough wire that the resistance of the wire causes no more than a 1-volt drop with the highest expected current flowing. Today, with a typical motor drawing about .3 amps under load, a three unit consist will only draw about 1 amp. Thus, a 1-ohm total resistance would satisfy this guideline. Heavier gauge wire will result in less loss.

Then, consider the round trip wire path from the power pack or booster to the most distant block and back. Select a wire size from the following table based on the total wire path length.

Table 6-1 Resistance Table for Wire

Wire Gauge	Ohms per 100 feet of total length
26	4.08
24	2.57
22	1.61
20	1.01
18	0.64
16	0.40
14	0.25
12	0.16
10	0.10
8	0.06
6	0.04

For the layout common wire, to which all of the common rails are connected, all of the train running current will pass. This means that you need to count the entire current load from all of the trains that may be running at the same time. Also, with train detection boards installed, the voltage drop should be less than about 0.25 volts. This normally means that the layout common wire will be fairly heavy, with 8, 10 or 12 gauge sizes being used often.

Let's say that the total length of your layout common wire is 100 feet, and that the total current of all operating engines and cars with lights, etc., will be a total of 5 amps. The total resistance, to give a worst-case voltage drop of 0.25 volts, would have to be 0.05 ohms. From the table above, 8 gauge wire would be close enough. One good source of such heavy wire is the electrical department of a major hardware store. You can get

10-gauge stranded wire (type #17) for about 10 cents per foot as this is written. Use two 10 gauge wires together to get the equivalent of 7-gauge wire and a slightly lower total resistance.

Table 6-2 lists all of the block specific connections on the BD8 connector. Each of the eight blocks is listed, along with the connector pins assigned to common rail input, occupied and vacant outputs.

Use care in connecting these wires to the board connector pins, especially for the larger size wires. If you haven't had experience soldering connector pins like this, ask an experienced friend to help, or read about how to do it and practice. See NIRA data sheet D1g.10, "Soldering, Electrical and Electronic", for basic information.

Table 6-2 Common Rail and Output Connections

BLOCK	COMMON RAIL PIN	OCCUPIED OR EAST PIN	VACANT OR WEST PIN
0	1	7	H
1	2	8	J
2	3	9	K
3	4	10	L
4	A	11	M
5	B	12	N
6	C	13	P
7	D	14	R

Table 6-3 below lists all of the general purpose connection pins on the BB card connector.

Table 6-3 General Purpose BD8 Connections

FUNCTION	PIN(S)
Layout common connections	5, 6, E, F
+ 5 volt supply to LED signals	16
Signal Ground Connection	T
Protection Diodes for inductive loads	S
Power input Positive	18
Power input Negative	V

Connect your BD8 layout common connections to the layout common wire. Simply run a tap wire from at least two of the BD8 common connections to the nearest place the layout common wire. Pins 5 and E are a good choice. Make sure that you are carefully attaching wires to the pins on the edge connector. Avoid using too much solder, too much pressure, and too much heat.

Carefully strip the insulation off each of the wires in the layout common group, and solder the tap wire to each of them. Since this is a bare connection, fasten it to a screw, joist or L-girder so that it can't move and come into contact with any other wires.

Then connect the power supply provided with the BD8 to the card edge connector. The power supply is a cord with a low voltage DC output. As you receive the power supply, there is a plug attached to the end of the cable. Cut off the plug as close to the end of the cable as you can. Split the two wires back from the end for about 1 ½ inches, strip about ¼ inch of insulation from each wire and attached them to the card edge connector. The wire

with the white stripe gets connected to pin 18, the positive input. Connect the other wire in the power cord to pin V.

To see if all is well, plug in the wall module. The BD8 “power on” LED (labeled “D18” on the board) should glow brightly. If it doesn’t, there are a couple of possible problems. First, the socket you plugged into must be on. Second, the wires to pins 18 and V may be reversed. Finally, there may be a short circuit on one of your connections to the card edge connector. Track down the problem before continuing.

6.3 CONFIGURING YOUR BD8 DETECTOR

The BD8 has a total of four self-test functions, and four operational functions. We call these the “modes.” You can change the mode of the BD8 at any time by simply adding or removing the jumper plugs on JP1 of the BD8 PC board. Within two seconds, the function will change to the one you have just selected.

In normal operations, you will simply set the mode required by your layout and leave it. From then on, whenever you turn on your BD8 it will start in your operational mode and give the type of output indications you wish.

But, in addition to that, the four self-test modes are available to help you with your installation, or to help trouble shoot problems if they should arise. All of the modes are described in the paragraphs that follow. And each includes a figure showing the correct jumpers to install.

6.3.1 NORMAL OPERATIONAL MODES

There are a total of four operational modes for your BD8. Unless you change your layout control system at some time, you will probably never have to change modes. But you always have the choice.

6.3.1.1 Command Control

Use this mode if you are using any form of command control. Your outputs will indicate the OCCUPIED or VACANT status of your blocks.

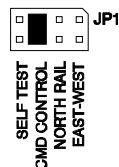

Figure 6-5 Command Control Jumper Positions

6.3.1.2 DC Control, Occupied-Vacant Output

For DC controlled layouts, this will be the most likely mode to use. The outputs are OCCUPIED and VACANT, and will operate two aspects at trackside. Or, you can use the OCCUPIED output to activate LED’s on control or TC panels to show train positions. This would be especially helpful where hidden track is involved. Note that no jumpers are used for this mode.



Figure 6-6 DC Control, Occupied-Vacant Output

6.3.1.3 DC Control, East-West Output, South Rail Common

The EAST-WEST outputs are used with DC controlled layouts primarily to indicate the direction a train is moving. You may have need of this to help operate hidden track. With two adjacent LED's on a panel, both will be on if a train is present and standing however, as soon as you connect a cap on its throttle a bit, one light will go out. The remaining lit LED will show which way the train will move. This is a real help, particularly with new or inexperienced operators when they are told to bring a train out of a hidden staging yard.

If, in addition to the EAST-WEST output you would like to have a separate OCCUPIED output, or both OCCUPIED and VACANT outputs, you will need to provide some additional circuitry.

With EAST-WEST Detection, your BD8 needs to know which of your rails is the common rail. In this mode, the SOUTH rail is your common rail.

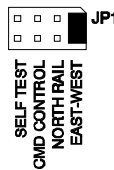

Figure 6-7 East-West Reporting, South Rail Common

6.3.1.4 DC Control, East-West Output, North Rail Common

This mode is used to obtain EAST-WEST output and status for DC controlled layouts with the NORTH rail as the common rail. In all other respects, this mode is the same as the mode described in Section 6.3.1.3.

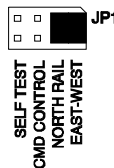

Figure 6-8 East-West Reporting, North Rail Common

6.3.2 SELF TEST MODES

The four self test modes are used to help with the installation of your BD8, and to assist you in trouble shooting should any problems develop in the future.

6.3.3 SOFTWARE VERSION NUMBER

Your BD8 includes a processor with a program developed by us to perform all of the functions you have seen described in this manual. While we have tested the board under a wide variety of conditions, we cannot anticipate every possibility of layout control system, throttle design, or advance in various technologies.

To help you and us keep track of any changes that take place in the software we have included a way for you to read out and record the version of the software programmed into your processor. If it should become necessary to help you with some problem you are having we may need to know the specific version of the software your board is using.

To record this, put your BD8 into this mode and record which blocks are occupied and which are vacant. Simply write "ON" or "OFF" in the two columns of Figure 6-4. In this mode, the BD8 is not detecting trains; it is using the 16 outputs to report its version number.



Figure 6-9 Reading the Software Version Number

Check each output from your BD8, and mark down for each block that outputs are on. Note that it is possible for both outputs to be on, depending on the specific version number being reported.

Table 6-4 Record of Software Version Number

BLOCK	OCCUPIED OUTPUT	VACANT OUTPUT
0		
1		
2		
3		
4		
5		
6		
7		

6.3.3.1 Rapid Sequencing of Outputs

In this mode, your BD8 very rapidly turns on and off each of the outputs. This gives you a quick check to see that all outputs are functioning, and that the wiring between the outputs and your LED's, bulbs or relays are functioning.

The sequencing is probably too fast for your relays to operate. And your incandescent bulbs cannot blink at full brightness, but your LED's should light fully, although briefly.

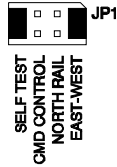

Figure 6-10 Rapid Output Sequencing

In this mode, your BD8 is not detecting trains; it automatically activating its outputs in a high speed sequence. This is the same sequence as the slow East-West sequence, but the entire scan plate 3 times per second, rather than once in 64 seconds.

6.3.3.2 Occupied-Vacant Sequencing of Outputs

In this mode, your BD8 turns on and off each of the outputs at a time. Each output is on for two seconds. This is enough time for bulbs and even relays to respond. You can activate this mode by placing the mode jumpers as shown and then watch your signals turn on and off in a known sequence.

Beginning with the block 0 outputs, first the vacant output will turn on. After 2 seconds, the vacant output will turn off and the occupied output will turn on. After two more seconds, it will turn off and the block 1 vacant output will turn on. This sequence repeats from block 0 to block 7, and then starts over for as long as you leave the BD8 in this mode.



Figure 6-11 Slow Speed Occupied-Vacant Sequencing

When using this mode, watch your outputs carefully. See that each turns on and off in the proper order. If something doesn't operate properly, track down the problem beginning at the BD8 output.

When an output is on, you can measure 5 volts DC if you put your voltmeter's positive probe on the BD8 5 volt output pin (16), and the negative probe on the output pin you want to check. Measured this way, an output will show 0 volts when off, and 5 volts when on.

If you are using the BD8 with an external power supply for your output devices, such as relays or bulbs, you will need to measure in a slightly different way. Set your voltmeter for the voltage of the external power supply, and put the positive probe on the positive output of the external power supply. As before, put the negative probe on the BD8 output you want to check. You should read 0 volts when the output is off, and the voltage of the external supply when it is on.

Of course, the first thing you should do is make sure that the BD8 is turned on. Check the D18 LED on the PC board and verify that it is at full brightness. If you are using an external power supply, make sure that it is on.

If the output is working properly at the BD8 card edge connector, but the output device (LED, bulb, or relay) is not working, repeat the voltage measurement at the output device itself you don't get the correct voltage

readings, check the wiring between the BD8 and the device. If you do get the correct voltage readings, check the device itself.

6.3.3.3 East-West Sequencing of Outputs

This mode is very similar to the Occupied-Vacant Sequencing of Outputs described above. Other than the positions of the mode jumpers, all of the comments above apply, except that the output sequencing is different.

For this mode, each step of the sequence again takes seconds, and the pattern begins with block 0 and runs through to block 7. The outputs have the pattern: OCCUPIED-VACANT-BOTH-NEITHER.

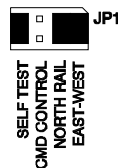

Figure 6-12 Slow Speed East-West Sequencing

Again, if you see something that isn't working, use your voltmeter to make the voltage measurements described in Section 6.3.3.2.

6.4 CONNECTING TO THE TRACK BLOCKS

This section deals with connecting BD8 to each of the blocks on the board. The goal is to detect a block at a time, and test as we go, to keep from creating any big problems.

1. Pick a block to connect to the DB. For your first block, pick one that is easy to get to. Let's make the learning process as easy as possible. The block will still have your original wires from the cab select switch to the common and power rails running to the block.
2. Our first step is to electrically isolate the common rail from the layout.
3. Cut the common rail feed wires so that at least a few inches of useable wire remains attached to the rails. And then make sure that the common rail is separated by gaps from all adjacent blocks and frogs.
4. Test the block to make sure you have isolated the common rail. Do this by trying to run a train in the block and all connecting routes. If the train runs anywhere in the block, you still have one or more common rail feeds that need to be removed from the block.
5. When all common rail has been isolated, run a new common rail feed from the assigned detector in the DB to each of the now cut common rail feed wires dropping down from the common rail. Again, when this is done, you should be able to run your train anywhere in the block. Try it and see. If the train doesn't run in some portion of the block, you still have a common rail feedwire to connect. Keep looking till you find it and connect it to the BD8. Table 6-2 Common Rail and Output Connections lists the connector pins used for each of the eight detectors.

6. After you have connected the block common rail to the detector, connect the outputs for the same detector. See Section 6.5, **CONNECTING THE OUTPUTS** for specific information on how to connect to the DB. Choose the paragraph that describes the output device you are using.
7. When you have the output connections installed for a block, check them by using one of the three self test modes which sequence through the output steps. **Suggestion:** Use either slow speedscan for this test. Also, remember that there are 16 steps in the occupied-vacant sequence, and each step takes two seconds. There are 32 steps in the east-west-both-neither sequence, also about two seconds each. So it will take a while for the BD8 to cycle through all of the steps.
8. Double-check the wiring if the outputs for the block do not function as you expect. With these self-test modes, the BD8 isn't doing train detection - it's simply operating the outputs. So any problem will be somewhere in your output wiring or the power supplies you are using for the output devices.
9. Finally, when you see that the outputs operate properly, then set the BD8 to the operational mode you will be using, and again run a train everywhere in the block, and through all connecting routes. Watch your output devices, signals, bulbs, panel LED's, dials, or whatever you have, and see that they activate properly as your train enters or leaves the block.
10. When your first block is working, pat yourself on the back, take a break, then repeat the process for the remaining blocks!

6.5 CONNECTING THE OUTPUTS

The BD8 outputs are limited to 150 milliamps each. Naturally, you can use much smaller wire for these circuits, especially if you are only operating LED's or logic signals. For the latter cases, the current per output will be less than 20 milliamps. You could probably use all ribbon cable if appropriate for your situation. Even though it is normally about 28-gauge wire, for such low currents it won't matter - unless your layout is as big as Yankee Stadium.

If you are using the BD8 to generate logic signals, take care to provide a good ground path between the B "common" pins and the ground connector for your other logic. Also, remember that the BD8 common is connected to your common rail circuit. Make sure that your other logic shares this connection. Finally, just connect the desired BD8 output on the card edge connector to the logic circuit you have.

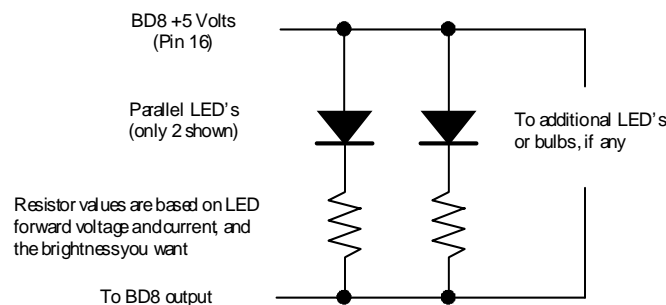

Figure 6-13 Driving Multiple LED's From a Single Output

Figure 6-13 Driving Multiple LED's From a Single Output shows how to drive two LED's from a single BD8 output. You must calculate the proper resistor values based on the LED's use. Typically, an LED has a forward voltage drop of approximately 1.7 volts. To calculate the proper resistance value, subtract the forward voltage drop of your diodes from 5 volts (the BD8 power supply output voltage) and divide the difference by the diode forward current.

Color light signals use a single, individual color LED to display each aspect. Normally, these will be GREEN and RED LED's to represent the PROCEED and STOP aspects. Figure 6-14 LED Resistor Installation Method below shows how to connect the two LED's of a signal if you only need to display the aspect at a single location, trackside or on a panel. Since only one LED is ever on at the time, you only need one resistor to limit the current. However, since red LED's are normally much brighter than either green or yellow LED's, many people use a higher resistor value for the red LED so that its brightness matches the brightness of the other two colors.

Perhaps the simplest way to connect the BD8 outputs to signals using LED's or incandescent bulbs is to use four-conductor modular phone cord. This wire is readily available everywhere (try Radio Shack), is large enough to carry the required current, and is very low in cost. We recommend that you use the black wire for the +5 volt connection, and the red and green wires for the corresponding LED's.

Which leads us to the question of how and where to install the current limiting resistors. One method that works well, costs little, and is very reliable is described here. A three pin terminal strip is shown, but you could use a 6 pin terminal strip if you had two signals close enough that the leads would reach. Also, if you are planning to install 3 color signals someday, consider using a four or eight pin terminal strip now. You will need the extra pins later. At the time this is being written, you can call Muser Electronics at 1-800-346-6873 and place an order or request a catalog. Refer to Signal Mounting Adapters in the accessories section of the website.

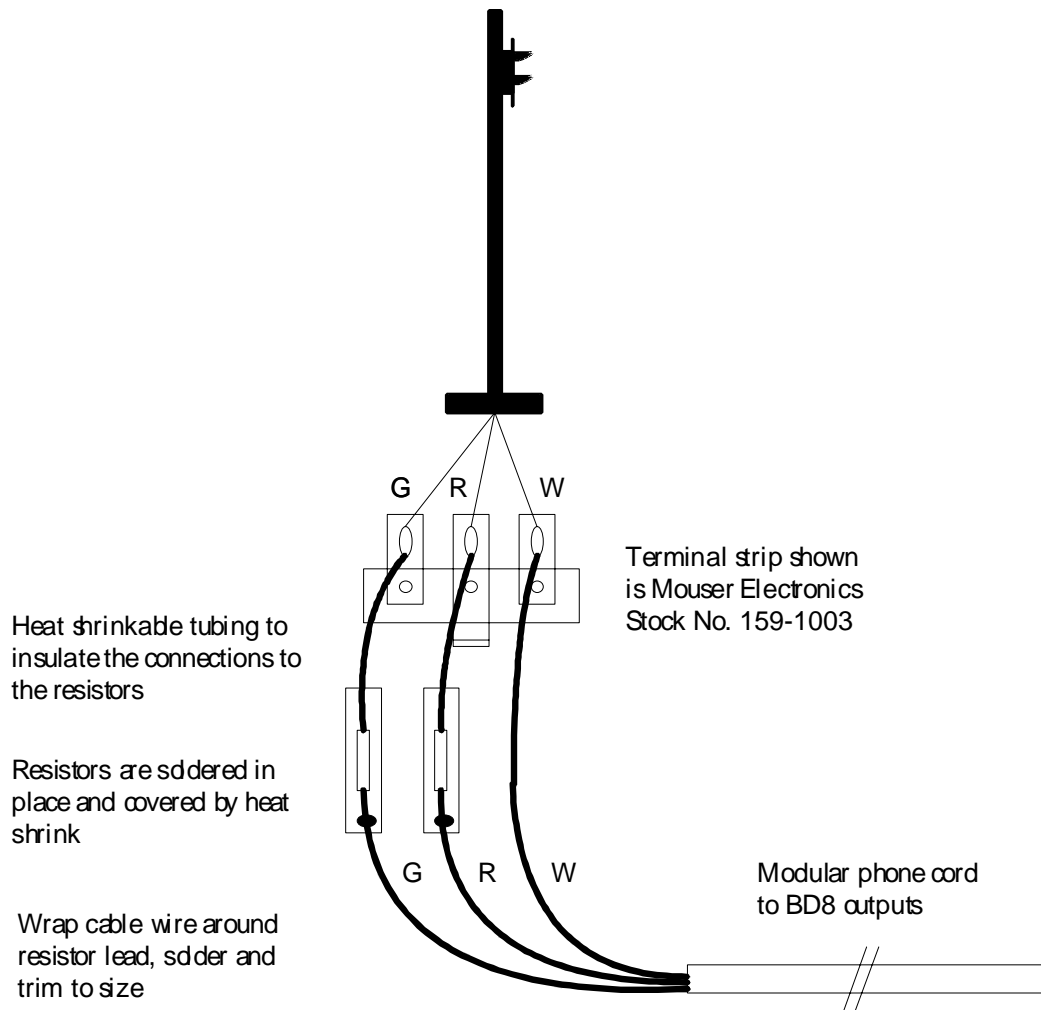

Figure 6-14 LED Resistor Installation Method

Let's work out a simple example to see how to calculate the current limiting resistors. Suppose your diode has a forward voltage drop of 1.7 volts, and gives the desired brightness with a current of 20 milliamps.

$$R = (5 - 1.7) / 0.02 = 165 \text{ Ohms.}$$

In this case, pick a standard value of 160 ohms for each of the resistors. Then, calculate the power dissipation of the resistor:

$$P = R \times I^2 = 160 \times 0.02^2 = 0.064 \text{ watts.}$$

In this case, a 160-ohm/4 watt, 5% tolerance resistor costing only pennies, would be just fine. Simply substitute the forward voltage and current of the LED's you use into these equations to select the proper resistors. As long as the resistor power rating is higher than the power calculated, you will be OK.

You can use the BD8 outputs to operate low voltage (typically 1.5 volts) incandescent bulbs in the same way as LED's. The connections are all the same. However, you must use an external power supply with incandescent bulbs. Such bulbs draw a high surge current when they are first turned on. This surge current

can be enough to overload the power supply. The power supply won't be damaged, but, when the supply drops too low, the processor chip resets and restarts. This causes the BD8 to operate incorrectly, or not at all.

The second difference is that your drop resistors will almost certainly be different values because bulbs normally draw a much higher current, not including the surge current. If you are using low voltage incandescent bulbs, check their spec sheet to see what voltage and current requirements happen to be.

Once again, recall that, with DC there can be no connections between the outputs of separate boosters. This includes any connections between pins on BD8 boards connected to separate boosters as well. If in doubt, please contact either the manufacturer of your DCC system or us for technical assistance.

When using the BD8 to operate inductive loads, such as motors or relays, be sure to use a protection diode as shown in Figure 6-15 with each such load. The protection diode is shown with dashed lines and shaded, because the BD8 includes diodes wired internally as shown. To them, simply connect pin "S" to the positive output terminal of your relay supply. This, of course, means that all of these inductive loads, relays and motors, connected to any particular BD8 have to operate off the same DC power supply.

They serve to protect the BD8 output chips from excessive voltages generated when these loads are switched off. Without them you will almost certainly blow out some integrated circuits.

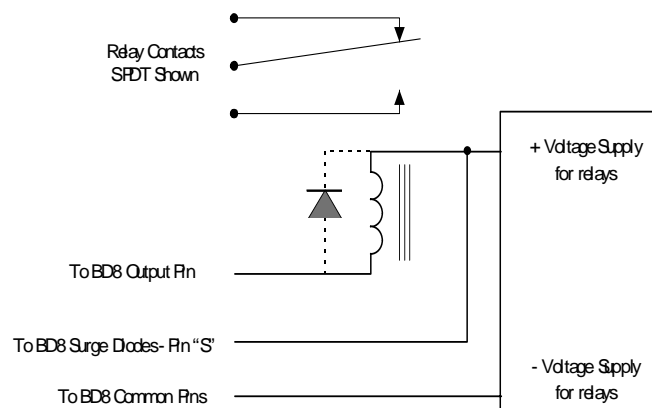

Figure 6-15 Connecting Inductive Loads

6.6 STANDING TRAIN DETECTION

For the BD8 to detect a train there must be some small current flow. If you are using command control, there will always be a voltage applied to the track, and the BD8 will always be able to detect the presence of equipment that draws even a small current.

Most cars, however, do not draw any current unless modified in some way. We stock non-magnetic replacement wheel sets for HO and N scale standard gauge equipment. These wheel sets are equipped with a resistor that allows a small, but detectable, current to flow. To make your cars detectable, simply replace one or two wheel sets per car with ours. On special order, we can provide wheel sets for other scales and gauges as well.

Or, you can make your own if you wish. We use a 5.1 K ¼ watt resistor bridging the insulation between the axle and the insulated wheel.

With a DC controlled layout, a special arrangement is necessary to make sure that there is always a voltage applied to each block. We recommend that you install a 12 VAC transformer as shown in Figure 6-16, and connect this voltage through a 4.7 K ohm resistor to each power rail of detectable blocks. Even when the cab select switches are in the OFF position, this very low current AC will be present.

Since this is an AC voltage, if there is a standing train present, the BD8 will detect a current that flows alternately in both directions. The change in current direction takes place 120 times per second, and we all know that a train can't really change direction that fast - it has to be standing still. The BD8 sees current flowing in only one direction, it concludes that the train is moving in the corresponding direction.

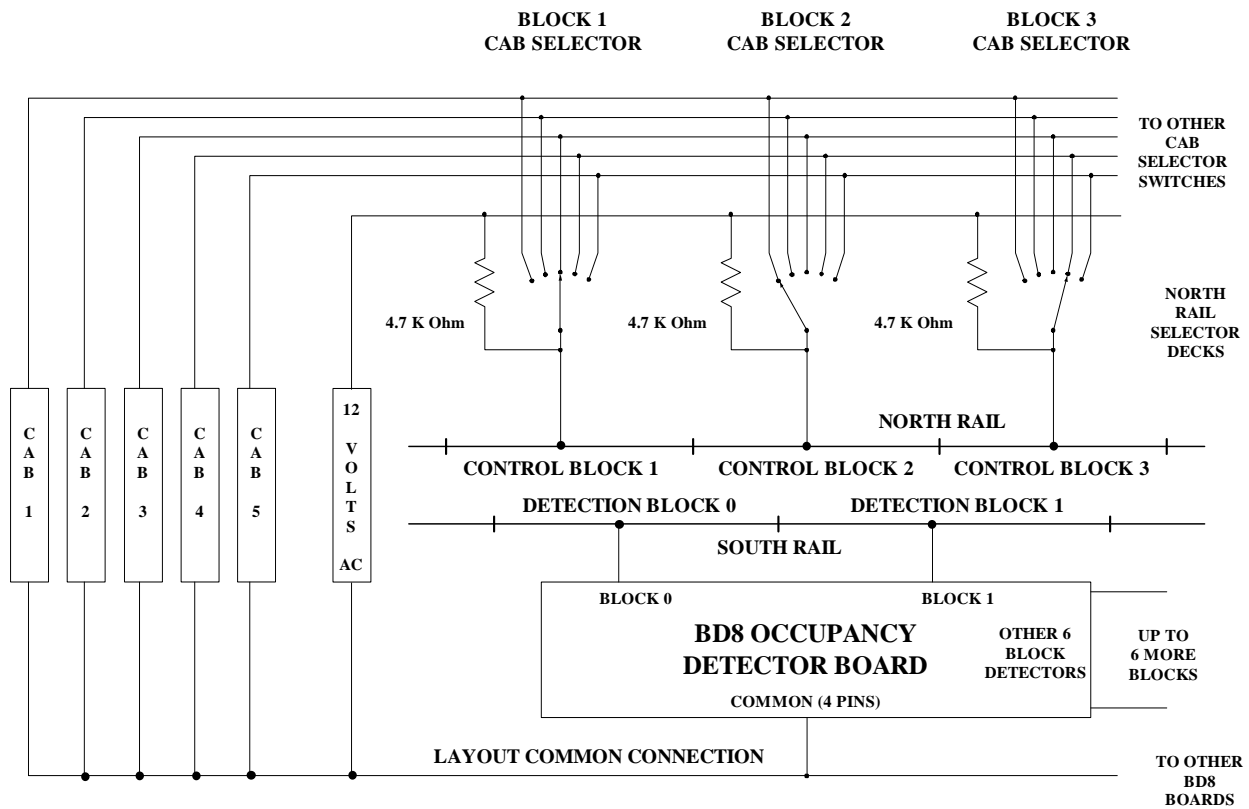

NOTE: Detection blocks (SOUTH rail) and control blocks (NORTH rail) can be different.
 Detection outputs from BD8 are not shown in this figure.
 12 Volt AC transformer must be isolated from cab circuitry.

Figure 6-16 DC Control With Standing Train Detection

We suggest that you use 4.7 K ohm, 1/4 watt axial lead resistors. They are readily available at low cost and are easy to install. A convenient method would be to install resistors for all of the blocks controlled by a control panel on an insulated counting board behind the control panel. Then, simply run a wire from one end of each up to the power rail output pin on each cab selector switch. Connect the opposite end of all the resistors together and then to the output of the 12 VAC transformer as shown in the figure above.

One good way to mount these resistors is to use what is called a "turret terminal board." Keystone Electronics Corp. makes several suitable ones. Their part number 15032 provides enough terminal pairs to install 25 resistors.

You can get these, along with the resistors, from various distributors. Allied Electronics (1-800-433-5700) handles the terminal boards (Allied Part No. 839-2373). You can get the package of 200 resistors from Digikey (1-800-344-4539) using their part number 4.7KQBK-ND.

6.7 TESTING YOUR BD8 DETECTOR INSTALLATION

We thoroughly test each BD8 before shipping it to you. But the time may come when you want to see for yourself that the board is working properly. Also, all of our built-in test functions operate the output signals in a predictable way. Thus, you can select one of the BD8 test functions and see if your lights operate as you expect. Make sure that you have recorded exactly which outputs go to which loads.

6.8 TROUBLE SHOOTING SUGGESTIONS

The step-by-step conversion and installation procedures detailed throughout this manual should help you avoid most problems, and quickly identify the rest as you go. The important thing is to make just one or two changes and see if everything is still working. If not, then solve the problem with what you did since the last test. The more you do between tests, the harder it will be to locate the problem.

Another benefit of the do a little and test approach to this is it helps you to build your confidence as you go. Success breeds success, and every time you see something that you did work right, no matter how simple or seemingly inconsequential, you will see that it's really not that difficult after all.

The next few paragraphs are a few additional suggestions for ways to prevent or at least identify problems.

- What if none of the signals work?

Suppose none of your signals work. If at least one of them used to work, and now they don't, the first thing to check is the power. The power LED on the DB board should be glowing brightly. If it isn't on at all, see if the power module is plugged into the wall, and the wall outlet is on.

Then check for a short circuit across the 28.5 volt power supply. There is a resettable fuse on the DB board that will protect the board electronics. But if there is a short you will have to eliminate the short and allow a minute or so for the fuse to cool before the circuit will reset. You should unplug the power module while you wait.

If this is the first time you have tested anything, and the power LED is not on, check the power as above. But also check to see if the power connections to the card edge connector are correct. Unplug the DB and measure from pin 18 to pin V directly below. You should measure 9 to 12 volts DC, with pin 18 positive. If the polarity is wrong, unplug the wall module, swap the wires to pins 18 and V, and re-measure the voltage. It should be OK. Then, turn off the line power, plug in the DB, and try again.

If you don't get any voltage out of the wall module cord, be absolutely sure that the 120 VAC power is on at the wall outlet. Plug a lamp or other line powered device into the same outlet and see if it works. If the wall outlet is working, and still you get no output voltage from the power module, contact us.

Also, make sure that, if you are using LED's, that the polarity is correct. If the power is on, you can manually activate any single LED by connecting the corresponding output pin on the edge connector to layout common with a test lead.

- First Test Wiring To Signals

If your signals don't seem to be working quite right, begin by running one of the following sequence self test codes. Watch carefully to see if the signals operate as you expect. Remember, the BD8 will activate block 0 outputs, block 1 outputs, etc. and then start over.

If the self test sequence is correct, and a problem seems to be that the wrong signals change when the train moves from block to block, then there is probably an error in the wires from the block common rails to the BD8 detectors.

If the self-test sequence is not correct, then there is probably an error in the output connections from the BD8 to the signals. Look for opens, shorts, wires connected to the wrong pins on the edge connector.

- Block always shows vacant

Normally, this would mean that the common rail lead from the block is not going to the proper detector input pin (1-4, A-D) on the edge connector. Or, it might be that you still have one of your original feed wires connected to the block common rail. This will keep the BD8 from detecting the train. Go back to Section 3 and go through the step by step conversion procedure described. This will help you solve the problem.

- Block always shows occupied

If the vacant LED never turns on, and the occupied LED always on, then you probably have a source of current into the BD8 common rail connection. This would appear to the BD8 that there is something in the block. See if the LED's switch when you disconnect the common rail input to the detector. If so, then look for some unexpected current source into the common rail. This could be a missing or closed gap, a wheel bridging a gap, or even an engine or piece of rolling stock being detected.

If both LED's are on when the block is vacant, and the vacant LED goes out when it is occupied, check the wiring to the occupied LED. You probably have a short to common somewhere along the wire from the BD8 output to the LED cathode.

- Standing trains are not detected

For the BD8 to detect a train, some current flow must be present if the block is occupied. With command control, power is always present on the track. However, with DC control, current flow stops when the cab stops its train, or when no cab is selected for a block. Thus, with DC control, some provision must be made to assure that small current flows even when the cab has stopped the train. A simple technique to do this is illustrated in Figure 6-16. This circuit puts a small AC current through an occupied block when the cab is off. When the cab starts its train, the DC current over-rides the 1 ampere or so of AC current as the train begins to move. This AC current

results in an interesting feature with the BD8: a stopped train will be reported as going both east and west! This is how we report a standing train if directional reporting is selected.

- Trains are not detected when Throttle at 0

Be aware that some electronic throttles have a very low output impedance, and act like what looks like a short circuit across the rails when the output voltage is zero. This will shunt the current provided by the resistors shown in Figure 6-16 and keep the BD8 from detecting the train. If, when you put the reversing switch in the center off position, this electronic short circuit is removed and the BD8 will report the block as occupied with a standing train.

There is a solution for throttles that don't bring their output voltage to zero when the train is stopped. We suggest that you install a full wave bridge rectifier in series with the throttle output. This works just like a constant lighting circuit, and allows current to reach the BD8 even with the throttle off. This is shown in Figure 6-17 Zero Output Throttle Modification below. Use a full-wave bridge rectifier with current rating at least equal to the maximum output current of your throttle. The voltage rating of the rectifier is not critical. Use the lowest available voltage unit you can find (50 volts PIV is a typical rating) for lowest cost.

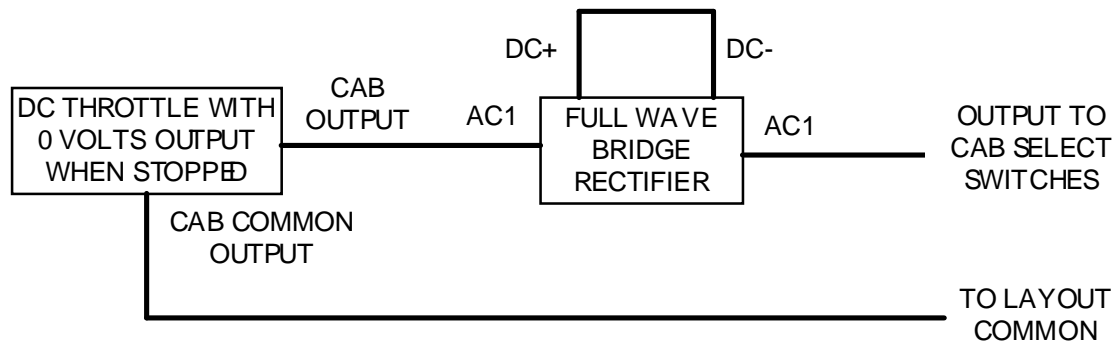

Figure 6-17 Zero Output Throttle Modification

- Strange operation of vacant blocks

If the signals in one block change when the train is near the block, you may have too small a layout common wire. Double check your estimate for the current in the layout common, and the wire gauge you picked. There could be a problem with this.

If this doesn't fix it, contact us by phone, fax or letter and let us know exactly what kind of "strange operation" you have. We'll probably have some questions (easy ones!) to help us understand your layout and installation, and then make some suggestions about other things to check.

Another possible cause for this problem has to do with command control. If the wiring to a block has a very large capacitance, any block detector may show a vacant block to be occupied. The BD8 has included special processing to minimize this effect. If, however, you have used twisted pair wires to connect to your blocks, very long runs of such wire could exhibit enough capacitance to cause the problem. To confirm that this is the problem

temporarily disconnect both wires of the twisted pair at both ends, and run separate feed wires that are not paired. If the problem goes away, then capacitance is your problem. Route the two new wires in a neat fashion and use them permanently.

- When all else fails

When you have done everything you know how to do, and have followed the installation and test suggestions in this manual, and still things aren't working, please contact us. We will do all we can to help solve the problem.

While our BD8 board may not be working correctly, this has not yet been the case. We have always been able to help our customers get everything working properly. We'll help you, too.

7. CUSTOMER SUPPORT

We understand that many model railroaders have limited experience or training in electronics, and may be somewhat apprehensive about installingigin detection and signaling systems. Our goal is to make our expertise available to those in the hobby who could benefit. We are doing this by developing products, and associated manuals, which take care of as many of the details as possible, and explain clearly how you can finish your installation and enjoy the additional operational features that are now possible.

If you have questions, or recommendations, please write. We will do our best to help you get the satisfaction available from your investment in our BD8.

7.1 TECHNICAL ASSISTANCE

We are available to provide reasonable assistance to help you get the greatest possible benefit from the BD8 Block Occupancy Detector. Feel free to write to us with any questions or comments you may have. Please enclose a large SASE if you are expecting a reply. We will do our best to clear up any issues you may raise about the use of the BD8.

We welcome any suggestions you may have for improvements to the BD8, or for any related products you would like to see available. All such recommendations will be considered as well as our future product offerings.

You can write to us at:

The Signaling Solution, Inc.
PO Box 25
West Terre Haute, IN 47885
VOICE: 812-533-1345 (9-4 cst)
FAX: 708-570-6140

7.2 LIMITED WARRANTY

Your satisfaction with the BD8 is our primary concern. The BD8 Block Occupancy Detector is warranted to be free of defects in materials and workmanship for a period of 90 days from date of purchase. This does not cover damage due to misuse, improper installation, or connection to excessive voltages or currents. We will, at our option, repair or replace any defective unit.

The BD8 Block Occupancy Detector is further warranted for 30 days to perform in a satisfactory manner when connected as described in this manual. Should you feel that your BD8 is not performing as you would expect, simply write to us, describing your specific type of installation, the type of electrical control system you are using, how you have connected the BD8, and details about what you expected of the BD8 and how it appears to fall short. If we cannot clear up any problem you have, we will refund your full purchase price upon return of your BD8 in good working order. Naturally, we cannot be responsible for units that have been damaged by misuse, improper installation or connection.

APPENDIX I

TERMINOLOGY

To allow us to discuss train control, we should begin by understanding certain basic terms.

ABS - Automatic Block Signaling, a system used to signal track for one direction of traffic flow. The signals will automatically protect trains from following movements.

APB - Absolute-Permissive Block Signaling, a system used to signal track for two directions of traffic flow. The signals automatically protect trains from both following and opposing movements.

BLOCK - a section of track separated electrically from other sections to allow trains to be controlled or their presence detected independently of all other blocks. Blocks on the prototype are used exclusively for detection purposes. On model railroads we use the word to describe track sections separated for detection and control. This latter use of the word "block" comes up in DCC control layouts.

CAB - a mechanism of some kind responsible for the speed and direction of a single train. It accomplishes this by controlling the voltage and polarity applied to the motor(s) of a train. There are various techniques carrying out this control.

CTC - Centralized Traffic Control, a system of train dispatching which allows a remotely located dispatcher to route trains through the automatic positioning of track switches and signal aspects. The actual track conditions, such as actual switch positions and the presence of trains, however, ride the dispatcher. His actions would cause an unsafe routing or signal aspect to be displayed.

COMMAND CONTROL - a train control system in which some "full" voltage is always applied to the track, along with a special electrical control signal that carries speed and direction information to many different trains independently. With command control, there are some number of separate, independent channels of communication between a central control station and receivers located in the engine. Each engine receives its own speed and direction information over an assigned channel, and then derives the voltage and polarity applied to its motor from the "full" voltage always present on the track. Different types of command control systems implement their communications channels and form of "full" voltage in different and usually compatible ways. There is now an NMRA Standard and related Recommended Practices for command control approved by the membership. We can all now take advantage of the NMRA Standard Digital Command Control (DCC) technology knowing that our investment in equipment to operate trains is protected by the existence of multiple manufacturers making compatible equipment. This has been the case with the NMRA Standard for DCC control for many decades.

COMMON RAIL - a method of wiring a DC control layout so that one rail is always considered to be at a constant, zero voltage. To control train direction of movement, the other rail would be taken to a positive or negative voltage. Table below shows how this works when your engines have been wired according to National Model Railroad Association (NMRA) standards. Note that train movement has nothing to do with the direction the engine is facing.

Table 1 Direction and Rail Usage

RR DIRECTION	COMMON RAIL	POWER RAIL	TRAIN MOVEMENT
East-West	NORTH	SOUTH & Positive	East-bound
East-West	NORTH	SOUTH & Negative	West-bound
East-West	SOUTH	NORTH & Positive	West-bound
East-West	SOUTH	NORTH & Negative	East-bound
North-South	EAST	WEST & Positive	South-bound
North-South	EAST	WEST & Negative	North-bound
North-South	WEST	EAST & Positive	North-bound
North-South	WEST	EAST & Negative	South-bound

If you have some personal dislike for common rail wiring" at this point, simply call the rails "A" and "B, or "NORTH" and "SOUTH"; trains will physically move the same way no matter what names we pick. **The only thing that matters to a motor is the voltage and polarity it sees.** The rail names are chosen to enable us to communicate with each other, and identify the specific items we are talking about. We choose a system of getting the voltage to a motor based on our operational needs and desires, and our available budget.

CONTROL BLOCK - an electrically isolated section of track used for the control of a train separate from all other trains on the layout. Control blocks are generally used only with DC control.

DC CONTROL - a train control system in which the layout is divided into many electrically independent control blocks, and a means is provided to connect only one of several cabs to a given control block at a time, allowing that cab to control the speed and direction of all trains in the control block.

DCC or DIGITAL COMMAND CONTROL - A form of command control described by the NMRA Standards and Recommended Practices. Command control operates by sending speed and direction messages through the track to decoders in each engine. Each decoder accepts messages sent to it specifically, and carries out the command. The typical commands will provide speed and direction information; additional commands can turn lights on or off, sound the bell or whistle, etc. The important thing is that these messages are sent to all trains, wherever they are on the layout. Hence, with DC, we can operate our trains exactly like the prototype - cornfield meets and all!

DETECTION BLOCKS - an electrically isolated section of track used for detection of a train separate from all other detection blocks on a layout. There is no need for control blocks and detection blocks to be identical.

EAST-BOUND - the condition of a detection block which has a train present and moving east.

HEADBLOCK SIGNAL - a signal that protects the entrance to or exit from passing tracks.

LED - Light Emitting Diode. A solid-state device that emits light, visible or IR, when a small DC current flows through it. They are very efficient, operate with little temperature rise, have very long life, and are good for use in signals or on control panels for indication switch positions or block occupancy

NORTH-BOUND - the condition of a detection block which has a train present and moving north.

OCCUPANCY DETECTION - a means for detecting the presence of a train in a block. Note that the blocks used to divide the layout for train control purposes can be different from the blocks used for detection. A main highway grade crossing provides a good example of the difference. For prototypical control of the crossing gates or flashers, three separate occupancy detectors should be used. There is no need or desire to provide for the control of separate trains in these three blocks. One train control block is sufficient.

OCCUPIED - the condition of a detection block which has a train present within it.

OS - On Sheet, or On Switch. The "On Sheet" usage applies to manual signaling and train control systems in which an operator will record the arrival or departure of a train "on sheet", a form used to keep a record of train movements and presence in blocks. The "On Switch" usage applies to automatic signaling systems that detect the presence of a train on a switch and prevent throwing the switch.

POWER RAIL - the rail parallel to the common rail. Since the common rail is at 0 volts, or "ground", the power rail is taken to positive or negative voltages with respect to the common rail to control the speed and direction of train movement.

RAILS - the parallel structures that the wheels roll on. For electrical purposes, rails need to have names. If your railroad runs east-west, you have a NORTH RAIL and a SOUTH RAIL. If your railroad runs north-south, you have an EAST RAIL and a WEST RAIL. While a particular rail is normally always NORTH or SOUTH, note that in certain special situations, such as frogs, turntables or reversing sections, a particular rail may change, depending on the route a train will take through the frog, or the assignment of NORTH or SOUTH to the adjoining rail in an adjacent section of track.

SIGNALING - the presentation of train presence or movement information to the engineers, dispatcher and other people involved in operating the railroad. For model railroads, this can be done to achieve scenic effects with trackside signals or grade crossing gate flashers, or to display train position on control panels to show train position in areas of limited visibility to the operators, such as hidden staging yards.

SOUTH-BOUND - the condition of a detection block which has a train present and moving south.

TRAIN DIRECTION - the direction the train is moving. For prototype railroads, direction is determined by timetable direction. On east-west roads, a train is moving either east or west. On north-south railroads, trains are moving either north or south. Sometimes the direction is determined geographically, other times the choice is arbitrary. For your railroad, you decide whether your trains move east-west or north-south.

VACANT - the condition of a detection block which has no train present within it.

WEST-BOUND - the condition of a detection block which has a train present and moving west.

APPENDIX II

OPERATIONAL FEATURES

1) CURRENT SENSING

The BD8 uses a pair of 3 amp diodes to generate a small voltage whenever current is flowing to something in a block: a motor, command control receiver, light or anything else that draws current. The diodes share a common ground return connection. Hence, a common rail power distribution must be used to power the blocks connected to any given BD8. Figure 3 Command Control Layout Wiring shows how the BD8 is connected in a typical command control system and Figure 2 Common Rail Layout Wiring shows the BD8 connected in a common rail DC control system.

The diodes are connected in series with the track feed to a block and will result in a voltage drop of approximately ± 0.7 volts. A current of less than 111 amp, and up to the current limit of 3 amps can be detected. To prevent burning out the diodes, your cabs should have some means for limiting their output current to 3 amps or less if a short circuit occurs. This only makes sense, even without the BD8, since the cab, rail, wiring and electrical switches should be protected from excessively high currents.

The detected current is processed to eliminate any detection chatter due to dirty track or wheels. Special processing is also required with DC controlled layouts to compensate for the effects of the high speed switching of the voltage applied to the track by boosters. All of this special processing is performed automatically by special circuitry included in the design of the BD8.

2) TYPES OF OUTPUT

The BD8 Block Occupancy Detector comes equipped for three different types of outputs and will also report occupancy in two different ways when used with DC control. These details are described below.

- **Output Capacity**

Included with the BD8 is a five volt power supply which will not only power the board itself, but will provide up to 400 milliamps of current to operate your LED's. For typical LED's with a current of about 150 milliamps, this works out to be at least three LED's per block that can be on at the same time.

The outputs, when active, will switch to ground, sinking current from a positive supply. If configured for LED or logic output, no additional power supply is needed unless the total load current required for the LED's exceeds the limit of the BD8 power supply. If configured to activate relays, incandescent bulbs or some other type of device, you must provide the compatible supply. Any such supply must have a maximum voltage of 16 volts DC above ground to avoid damaging the BD8 output integrated circuits. When operating signals with LED's included,

be sure the diodes are wired with their anodes in common. Other brands are also compatible if the diodes have individually wired cathodes. The anodes can be wired separately or in common.

Since each of the 16 outputs can handle 160amps at the same time, you can use the BD8 even if your needs exceed the current capacity of the internal supply. Simply provide an external power supply of the necessary voltage, not to exceed 16 volts DC, and providing sufficient current capacity. Use the external power supply to power your devices; use the internal power supply to power the BD8.

- **Occupied-Vacant Detection**

When used with a command control system or in one of two output modes used with DC control, the BD8 will report blocks as either “OCCUPIED” or “VACANT”. For each block, there are two outputs, one which is active when the block is OCCUPIED and the other when it is VACANT. The two outputs are mutually exclusive. Because of this, you can usually implement basic two color signaling without any additional circuitry.

For a prototypical, professional installation, you will want to interlock the signal aspects to the position of switches just as the prototype does. We have developed the SSI Switch-Signal Interlock Module to help you with this. It provides all of the necessary electronic connections to include its position in your signaling system. One connection to the SSI tells the circuitry the position of the switch; other connections from the BD8 (or BD16) Block Occupancy Detectors indicate block status. And outputs from the SSI go to signals on the frog and point sides to cause the proper aspects to appear.

- **Directional Detection**

When used with DC control, the BD8 can be configured to indicate not just occupied or vacant, but which way the train is moving if it is not standing still. This is particularly helpful if you are implementing some form of automatic progressive cab control, or using the BD8 to show which way trains are moving in hidden track.

You probably won't ever need this feature with command control; the throttle itself indicates true direction of travel.

There are still two output signals for each block. In this case, one will be active if the train is moving in east bound, the second if the train is moving west bound. If the train is standing still, or “moving in both directions”, both outputs will be active. If the block is empty, both outputs will be off. This is depicted simply in Table 2 below.

Table 2 Outputs for Directional Detection Mode

BLOCK STATUS	EAST OUTPUT	WEST OUTPUT
vacant	off = open circuit	off = open circuit
train standing	on = 0 volts	on = 0 volts
train moving east	on = 0 volts	off = open circuit
train moving west	off = open circuit	on = 0 volts

The BD8 has a mode jumper plug which plays a part in this. If your common rail is the south rail, install the jumper (Figure 6-7); if your common rail is the north rail (Figure 6-8), leave the jumper off.

- **LED Activation**

For many applications, such as two color signaling, the BD8 Occupancy Detector needs no additional circuitry. It can operate two color LED signals directly. Sufficient current capacity is available from the power supply provided with the BD8 to operate a total of 40 LED's of 10 milliamperes each, with all on at the same time.

Each LED must have a current limiting resistor connected in series with it. This is shown in detail in Figure 6-13 Driving Multiple LED's From a Single Output.

- **Logic Signal Activation**

The BD8 can be configured to output logic signals which can be used by the circuitry, such as three color signal control boards or progressive cab control circuitry. Since the BD8 provides what are known as "open collector" outputs, you simply connect a BD8 output to the desired TTL or CMOS input.

The input circuit will need, and usually comes equipped with, a pull-up resistor connecting the input to +5 volts. The resistor raises the input to logic high when the BD8 output is off; the BD8 output pulls the input low when it is on. Typically, these resistors will have values of 1000 ohms or greater. Our TC4 uses 10,000 ohm resistors.

All of the filtering used to minimize the effects of track and wheel dirt is still operational. No additional power supplies are needed by the BD8 to function using this output mode.

- **Relay Activation**

The BD8 also has the output current capacity to switch loads of up to 150 milliamperes per output (16 total). However, the total load current could be far beyond the capacity of the power supply we include. To make use of the total output capacity, you will have to supply your own power supply. Also, if you are connecting an inductive load, such as a relay motor coil, to the BD8, you must also use diodes that protect the BD8 outputs from the voltage spikes which are generated when current is turned off in an inductive load. Such diodes are included on the BD8 circuit board. How to use the diodes is illustrated in Figure 6-15.

3) BUILT-IN SELF TEST

The BD8 is a truly unique product in that it provides built-in test functions that will help you to test and trouble shoot the board itself and your installation. Other than our own BD16 Block Occupancy Detector Board, we know of no other train detection product that provides you with this feature.

First, the board has a power-on LED which glows bright when the internal power supply is providing full output. If this LED is off or dim, you know that something is drawing too much current from the power supply or that the power supply is not plugged in. Next, by using the mode plugs provided with the unit, you can have the BD8 sequence each of its outputs on and off in two second steps rapidly if all you need is a quick check. Everything you need to know to take advantage of the test functions is provided later in this manual.

APPENDIX III

OCCUPANCY DETECTION AND REPORTING

You may have many reasons for installing a system which reports the presence or absence of trains in various sections of track: displaying train locations to operators, progressive cab control, trackside signals, grade crossing gates, sound effects, etc. There are several different techniques available for doing this. If we overlook any particular technique, it is not to give offense.

The next few sections discuss some of the options available for detecting trains, along with their strengths and weaknesses. As you will see, the BD8 successfully covers every limitation normally present in occupancy detector systems.

1) OPTICALLY BASED SYSTEMS

An optically based detector uses a light source and light detector arranged so that the train physically prevents the light from reaching the detector when it is present. These systems have the benefit of being totally isolated from train running power. They can therefore be used on any layout, no matter how it is wired.

But they also are limited in that the light source and detector have to be positioned so that the train blocks the light. This means that they only detect at a single point. To detect trains throughout a block, many detectors, with overlapping fields of view would be required. Also, depending on the specific design the visual system can be sensitive to ambient light or the stability of the voltage powering the system. Empty log cars can be very difficult to detect in any case since they have little cross-sectional area available to block the light beam.

Sometimes people attempt to provide detection for long or serpentine blocks by using detectors at the beginning and end of a block, a technique called gate detection. This can work well if trains always move through the block. But what if a train enters, and then backs out? Or stops completely, say between operating sessions? What if the train separates? Or can leave through or enter through multiple paths? These are all factors that tend to limit the use of optical detectors for signaling detection purposes.

But this doesn't mean that optical detectors have no place in train detection. Use them to take advantage of their real feature: the detection of a train at a single point. Use them to help spot cars at difficult to see locations, to position hopper cars exactly right for the rotary car dumper to work perfectly, etc.

2) MAGNETICALLY BASED SYSTEMS

Magnetically operated detectors typically use a reed switch along with a permanent magnet to perform detection. The reed switch is activated by the presence of a magnetic field. Increase the magnetic field by bringing a magnet close and the contacts switch; move the magnet and the contacts open.

Normally, the reed switch will be buried in the ballast between two ties, and magnets will be attached to the bottoms of engines and perhaps cars. As the train passes, the magnet briefly activates the reed switch. Its contacts can be wired to logic or latching relays to show that a train has passed.

But this is just another version of gate detection system. All of the comments about optically based detection apply to magnetic detection. Except that optical detection seems to be better at detecting exact position than magnetic detection. And magnetic detection is not at all suited for detection over a "field of view" of any meaningful size.

3) SWITCHED ELECTRICAL CONTACTS

Several different techniques have been used over the years to detect trains using switched contacts of one kind or another. Sometimes they are activated by the light of the train passing over the electrical switch, and sometimes by the wheels physically contacting a wire mounted next to the rails.

Most of these systems are simple and cost effective. The weight operated switches seem to present a significant installation challenge. Getting them set up to operate with a relatively heavy engine (O scale) is fairly simple, getting them adjusted to operate with a relatively lighter (HO or N scale) is generally to induce a headache!

But all of these techniques operate in a gate mode, just like the optical or magnetic detectors, only detecting trains at a point. This really isn't occupancy detection, but such switching techniques can see some useful purposes. And, like all electrical contacts, switch operation can be impaired by dirt and oxidation. Even reed relays, which not sensitive to dirt, should have special alloy contacts if they are to function properly in low current logic circuits.

4) CURRENT DETECTION SYSTEMS

Current detection systems operate by detecting the current that passes through a motor or lights when a train is running in a block. There are many flavors of such systems, and they generally have similar advantages and disadvantages.

A major benefit of current detection systems is that they can easily detect train current, regardless of how long a block may be, or how the track is routed. And, as long as some current is present, they will respond properly to trains that stop, or enter and back out of a block. But they will generally introduce some drop in the voltage that actually reaches the motor. How significant this is depends on the specific technique used.

The next few paragraphs will describe the principle techniques of which we are aware.

- **Relay Current Sensing**

Specially designed relays have been used to detect the current flowing in a track circuit. In this case, the current passes through the relay along with the train motor and lights. Relays have several benefits. First, they are difficult to burn out, and, since the coil is electrically isolated from the switched contacts, properly designed relays can be used with any form of DC or even AC train control. And contacts can easily be designed to switch many amps, and thus control any type of load current.

The main limitation of this technique is the issue of balancing the sensitivity of the relay with the voltage dropped across the coil. As in most areas of engineering, there are conflicting factors that must be considered. With a relay, a magnetic field of a certain strength must be generated to switch the relay. To get sensitivity to low

currents, many turns of wire are required in the relay coil. The more turns there are, the higher the resistance of the coil and the larger the voltage drop; using heavier wire reduces the voltage drop but increases the physical size and cost of the relay.

In years past, when motors routinely drew an amp or more of current, a workable balance in the design of the relay could be reached. But today's motors, which draw only 20% as much current are much more difficult to detect. And when the train stops, so does the current. What is there to detect?

Relay contacts present a further limitation. They are subject to dirt and oxidation that can prevent the contacts from closing properly. Also, when used to switch the very low currents that are involved in logic circuits, typically a milliamp or less, the contacts should be plated to resist oxidation. Using gold increases the cost significantly; not using gold decreases the reliability significantly. Another one of those pesky engineering compromise situations!

Considering today's motor technology relays may not work at all. In fact, we haven't seen or heard of any used relays for train detection and also using modern can motors in the engines.

- **Transistor Current Sensing**

The transistor was first applied to train detection to our knowledge, by Lynn Westcott in the mid 1950's. He designed the Twin-T circuit, and later the Twin-T with booster transistor, for train detection. His circuits were very effective, and in wide use. They had the advantage of high sensitivity, resulted in a low and almost constant voltage drop in the track circuit. They could easily detect milliamp sized currents. By equipping your wheel sets with a resistor of some relatively large value, these circuits could detect a lone car pack or a block - just as the prototype does!

For practical reasons, the layout will usually be wired using common rail wiring, with the Twin-T circuit installed in the path from the common rail to the layout common return. You can avoid the need for common rail wiring by providing a separate, isolated power supply for each detector. This, of course, adds a lot to the cost.

The major limitation of the Twin-T circuit is the fact that the full train running current passes through what is normally a low current path through a transistor. Thus, relatively large and expensive power transistors had to be selected so that the base to emitter path could handle at least three to five amps. And these transistors had to be mounted on a heat sink of some fair size.

The only other limitation of which we are aware is the fact that these circuits operate very quickly, and can respond easily to momentary breaks in current due to dirt on rails or wheels. This effect can be reduced somewhat by installing a capacitor in the right place.

This form of detection is still adequate, but it is no longer cost effective to use such high current transistors to carry the train running current.

- **Diode Current Sensing**

The next form of current detector uses diodes in the common rail path to the block. Very low cost diodes, capable of handling 3 amps or more continuously while giving a voltage drop of less than 1 volt, are readily

available. This has the same effect as the power transistors used in the Twin-T circuit, at a much reduced cost. Sensitivity can be just as high or even higher.

The only thing remaining is to sense the voltage drop across the diode using an operational amplifier or comparator of some kind. Today such integrated circuits are readily available at low cost. Once the voltage has been detected, it can be conditioned to drive light emitting diodes (LED) or logic circuits.

Techniques of this type result in reduced costs when compared to Twin-T and similar transistor based circuits. They also operate very quickly and will respond to breaks in current flow due to dirty rail or wheels. As with Twin-T circuits, this can be controlled with a capacitor or other filtering in the right place.

Generally, two diodes are used, connected in parallel of opposite polarity. In this way, a positive voltage is generated when the train current is flowing in one direction, and a negative voltage is generated when the current flows in the opposite direction. This usually requires that the detector board have both positive and negative operating voltages applied, adding in the form of an extra power supply.

The BD8 Occupancy Detector uses an advanced form of diode detection, and a special technique that eliminates the need for dual power supplies to power the board. Special circuitry and signal processing techniques are provided which minimize the sensitivity to wheel and rail dirt.

- **Isolated Current Sensing**

There are several forms of isolated current sensing in use. An isolated detector operates much like a relay; a circuit element is wired in series with the block, and a electrically isolated signal is picked off and used to indicate train presence. One such technique uses four high current diodes in series with the track circuit, and two optical isolators. Depending on the direction of current flow, one of the two optical isolators activates.

Since the current sensing diodes are isolated from the rest of the detection circuitry by the optical isolators, this form of detector can be used even on tracks that do not use common rail wiring. The system is fairly sensitive, and appears to have, as its primary weakness, a series voltage drop of about 2 volts because there are two series diodes in the track current path. Noise filtering circuitry must be provided to minimize the effects of wheel and rail dirt. And additional signal conditioning must be provided to allow such a detector to operate LED's, relays, or bulbs.

APPENDIX IV

TRAIN CONTROL SYSTEMS

Over the years, many different systems have been developed for controlling model railroad trains. Today, there are two primary ways of controlling trains: DC control and Command Control. Both systems share the same goal: allow each engineer to control the speed and direction of his train. They differ in the way they achieve this goal, and the electrical complexity and operational flexibility provided.

Incidentally, the BD8 does not control trains. It simply detects the current flowing to 8 different sections of track to determine whether or not trains are present in those separate sections, and possibly which way they are moving.

We do have some customers who have used our detector boards to activate relays when a block is occupied, and use the relays to break the current to the prior block to prevent rear end collisions automatically. This is particularly helpful for modular layouts when they are operating for the public. It is sometimes difficult for the crew to converse with the spectators and keep the trains under control.

This lengthy discussion of train control methods and wiring is to help you to connect the BD8 into whatever train control system you now have, or to help you modify your present system so you can use the BD8. It will also provide some suggestions for using the BD8 to handle certain typical situations that arise on any layouts.

1) DC CONTROL SYSTEMS

With DC control, the layout is divided into many electrically separate blocks so that the speed and direction of trains in different blocks can be controlled independently. However, all trains within a given block receive the same voltage and polarity, and will therefore move in the same direction, and as determined by the specific motor and gearbox, at more or less the same speed.

People use countless ways for generating this voltage: batteries, variable transformers, DC supplies with rheostats, DC supplies with various forms of transistorized or integrated circuit voltage control circuits, SCR controls, and even motor-generator sets!

Such layouts have at least two cables and some method for the connecting cables, one at each block. Many different systems have been developed over the years, and you hear names such as cab control, tower cab control, route cab control, progressive cab control, and more. All of these systems were developed to allow multi-train operation on a layout. The whole purpose is to allow different engineers to operate their trains over the layout with as little interaction and confusion as possible.

Regardless of the details involved in generating the voltage and current used to run each train, the power routing system takes only two forms: two rail switched systems, and common rail switched systems.

- **Two Rail Switched Systems**

Two rail switched systems have circuitry that routes both rails of a block to the assigned cab. In this case, all cabs are totally independent electrically and all blocks are totally independent. While this seems like a simple, straight-forward system it does require almost twice as much wiring as is needed with common rail systems. Every switch must be a two-pole switch. Figure 1 provides an example of a layout wired this way

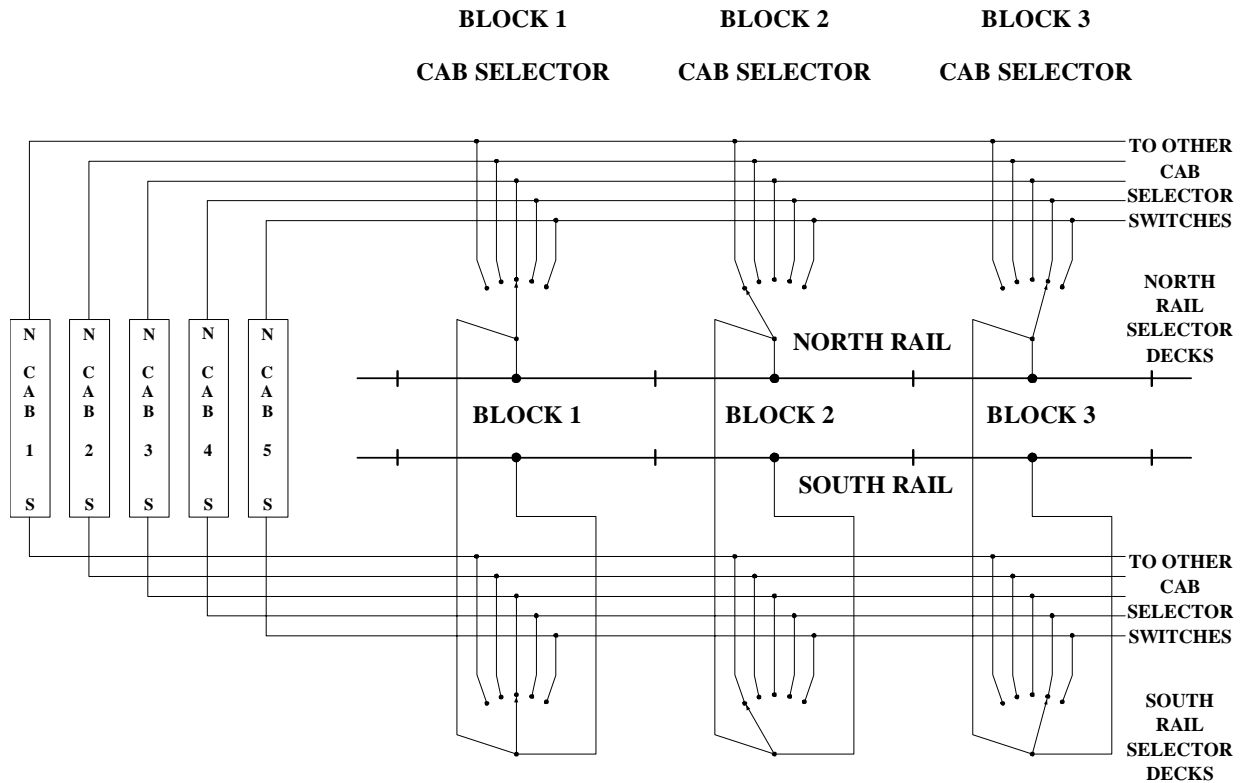

Figure 1 Two Rail Switched Cab Circuits

While this system works, it does not provide any advantage for operating your trains. Because there are twice as many switched electrical contacts between a cab and an engine, reliability is lower. This method also complicates occupancy detection since the detection circuit for each block must also be electrically isolated. Such detectors exist, but are somewhat more expensive than detectors that can share an electrical ground connection.

- **Common Rail Systems**

Common rail electrical systems consider one of the two rails always to be at zero volts, or “ground”. Train direction is controlled by setting the polarity of the other rail relative to the common rail: positive voltage will move the train in one direction, negative voltage in the other. Either rail can be selected as the common rail; the choice is entirely arbitrary. But a given layout must have the same rail as common throughout. Figure 2 below shows a layout wired using the common rail method.

Why use a common rail wiring system? There are two good reasons. First, since the common rail is always at the same voltage, namely 0 volts, you don't have to provide any switching for the common rail when connecting cabs to blocks.

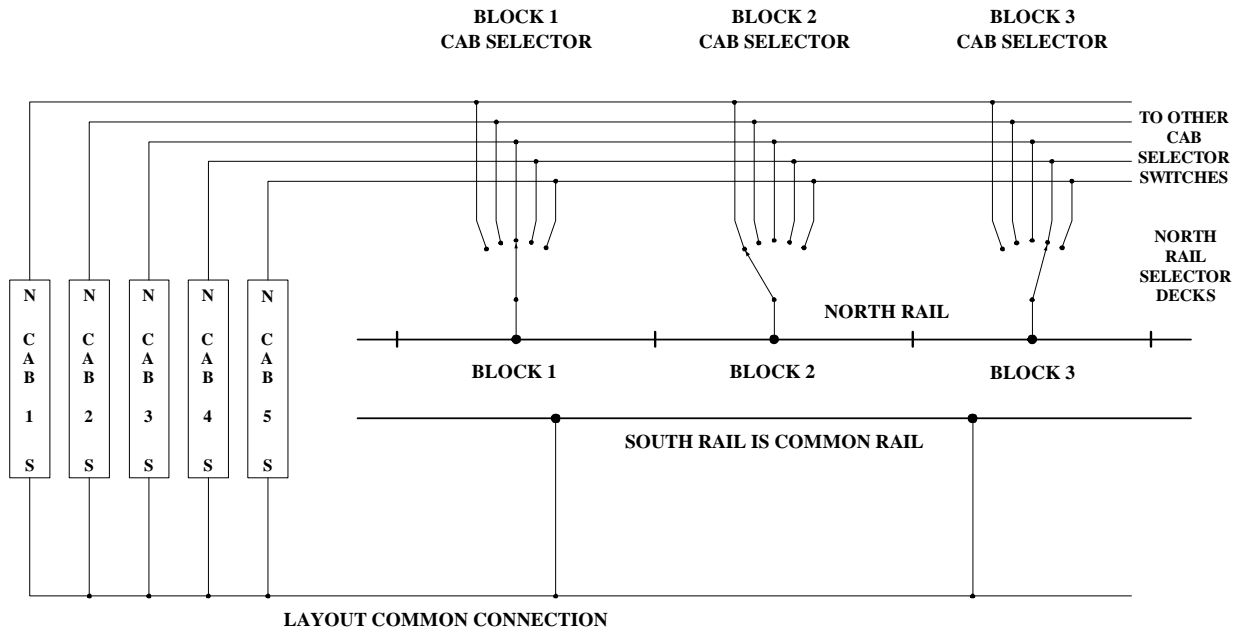

**NOTE: Only NORTH rail gapped at block boundaries.
SOUTH rail leads installed to provide low resistance path to cab
Cabs are internally isolated from each other electrically.**

Figure 2 Common Rail Layout Wiring

Second, since the common rail is always at the layout common voltage, very simple circuits can be used for train detection by connecting the common rail through the detector circuit layout common. Such detectors usually cost less than isolated detectors.

Sometimes modelers express the feeling that common rail wiring cannot be used for certain railroad track configurations. In each case, these modelers have tried to select their common rail using a rule such as "the right hand running rail is common". Please, please, do not use these rules. In a sense, they are correct: THAT RULE WILL NOT WORK.

However, if you use a rule that says "the north rail is common", you will have no problems whatsoever. Pick the north rail, or the south rail if you prefer, but use the same rail as the common rail everywhere on your layout.

If you use DC control, the BD8 will only work if you use common rail wiring for your layout. Converting a two rail switched layout to common rail is simple - if the cabs are electrically isolated. Simply pick a rail to be used as the common rail, and then tie together all of the cab lines that connect to that rail, bypassing whatever cab select switches you may have.

Only reversing sections need to be added with both rails isolated. This allows you to reverse the connections to these rails to match the polarity of these rails as a train enters and exits the reversing section.

Some additional modifications may be necessary if you are routing power through track switches or from that in Section 5, POWER ROUTING THROUGH SWITCHES.

2) COMMAND CONTROL SYSTEMS

Command Control systems, and there are several good ones available, are gaining a share of the market. They offer the greatest flexibility currently available for operating multiple trains on a layout. As the NMRAs DCC standard gains wider acceptance, we can all expect this form of control used more and more. Figure 3 below shows the typical wiring for a layout using command control. While the different systems use their own methods for implementing the control and power stations, the layouts all seem to be wired as shown.

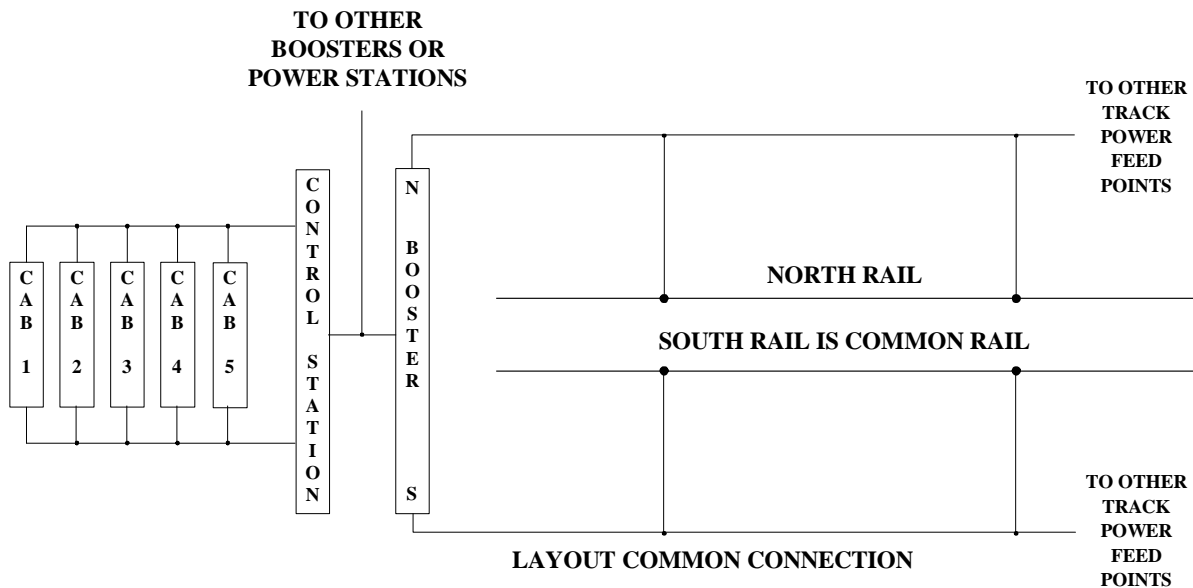

NOTE: Gaps are only used to isolate frogs, or to separate power stations.
 Think of the entire layout as one single block.
 Cab connections to control station depend on the specific command control system used.

Figure 3 Command Control Layout Wiring

With Command Control, full voltage of some form is always applied to the entire track. Included in this voltage is some form of electrical signal that is picked up by a receiver within each engine, and decoded to apply the desired voltage and polarity to the motor. Note that, ultimately, the motor needs a DC voltage and polarity to rotate and move the train.

There are various systems for embedding the control signal in the high current and voltage that appears on the track. These systems allow each engineer to control his train anywhere on the layout independent of what the other engineers are doing, and without routing power to blocks. In this regard, these systems are extremely successful. Using a command control system lets you have a cornfield or get careless!

Command control systems may, or may not, be common rail systems. Specifically, the NMRAs Standard DCC System uses "boosters" to provide power to the rails for the engines and other command decoders which are attached to the rails. For significant technical reasons, there can be NO connections between the outputs of different boosters. This means that separate BD8s must be connected to each separate DCC booster. As far as the output of

a single booster is concerned, its output "common rail" wired; but there is a separate "common rail" for the power district connected to each separate booster. All BD8 boards connected to the output of a given booster will share a single "common rail" within the associated power district.

Other systems have "power stations" of some kind which provide the combined power and control signal voltage to large amounts of track. Sometimes, particularly for large layouts with many trains running, you will want to divide the layout into several sections and power each from a separate power unit. This will help in finding short circuits since only the shorted section will stop functioning, and it also divides the current drawn by the engines among the power units. Most of the units have a current limit somewhere in the 4 to 8 ampere range.

To wire a layout for non-DCC command control, follow any specific instructions provided with your system. As far as we know, the BD8 Occupancy Detector Board works with all command control systems. Should you find that it doesn't, simply let us know within 30 days and we will provide a full refund upon return of your BD8 boards in working condition. Naturally, we are interested in getting whatever information we can about your command control system so we can design a detection system that is compatible.

**OTHER SIGNALING
AND LAYOUT CONTROL
PRODUCTS WE SUPPLY**

BD16 Block Occupancy Detector for 16 blocks
BD8 Block Occupancy Detector for 8 blocks
MSC Master Signal Controller
GCC Grade Crossing Controller
GCX Grade Crossing Expander
Detectable Wheel Sets
Signal Mounting Adapters
Optical Isolators

And our new CLICS™ System

COMPLETE LAYOUT INTEGRATED CONTROL SYSTEM